



Model B40i4 Operator's Manual



LANDOLL CORPORATION

1900 North Street
Marysville, Kansas 66508
(785) 562-5381

800-428-5655 ~ WWW.LANDOLL.COM

Table of Contents

1 Forklift Safety and Familiarity

Before You Begin (Please Read)	1-1
Site Supervision	1-1
Terminology and Illustrations Used in Manual	1-2
Understanding Safety Statements	1-2
B40i4 Decals and Placement	1-3
Operator Safety	1-5
Lock Out/Tag Out	1-6
Operator Safety Training	1-6
Seat Belt	1-6
Seat Safety Switch	1-6
Parking Brake	1-6
Tipping Hazards and Conditions	1-7
Longitudinal Tipping Can Occur When:	1-7
Lateral Tipping	1-7
Longitudinal or Lateral Tipping	1-8
Traveling and Load Handling	1-8
Speed	1-8
Visibility	1-8
Gas Engine	1-9
Engine Care	1-9
Service/Maintenance Safety	1-9

2 Receiving and Inspection

Items Furnished with Your Truck	2-1
Tools and Test Equipment	2-1
Preparing the Forklift	2-1
Inspecting the Forklift	2-1
Visual Inspection	2-1
General System Checks	2-2
Driver's Seat	2-2
Fasteners	2-2
Horn, Lights, Etc.	2-2
Hydraulic Lines and Loose Fittings	2-2
Hydraulic Oil Level	2-2
Dash Display	2-2
Stopping	2-2
Mast Operation	2-2
Overhead Guard	2-3
Parking Brake	2-3
Rust or Corrosion	2-3
Safety Decals, Data Plates, etc.	2-3
Tires and Wheels	2-3
Welds, Cracked or Broken	2-3
Wires or Connectors	2-3
Fire Extinguisher Option	2-3
Replacing the Battery	2-3
Storage, Towing or Shipping	2-4
Truck Storage	2-4

Towing the Truck	2-4
Shipping the Forklift	2-5

3 Understanding the Bendi B40i4 Forklift

Vehicle Description	3-1
Truck Identification	3-2
Identification Plate	3-3
Bendi B40i4 Mast and Frame	3-4
Bendi B40i4 Serial Number Code	3-4
Understanding Truck Rate Capacity	3-4
Truck Overview	3-4
Frame	3-5
Brake System	3-5
Parking Brake	3-5
Electrical System	3-5
Traction	3-5
LPG Gas Engine	3-5
Features	3-5
Keyswitch	3-5
Safety Interlock	3-6
Battery	3-6
Hydraulic System	3-6
Hydrostatic Drive	3-6
Auxiliary Pump Circuit	3-6
Steering	3-6
Hydraulic Fan	3-6
Mast Valve	3-6
Filtration and Cooling	3-6
Mast Controls	3-6
Mast Lift	3-6
Mast Tilt	3-7
Mast Side Shift	3-7
Mast Lift Assemblies	3-7

Driver Controls	3-8
Foot Control Pedals	3-8
Hand Operation Controls	3-9
Direction Lever	3-9
Lift Lever	3-9
Tilt Lever	3-9
Side Shift Lever	3-9
Horn	3-10
Rear View Mirror	3-10
Driver's Seat	3-10
Seat Belt	3-10
Steering Wheel	3-10
Switch Panel	3-10
Dash Display	3-10
Understanding Stability	3-11
Basic Principles	3-11
Load Center	3-12
Counterweight	3-13
Maximum Fork Lift Height	3-13
Tilting Considerations	3-13
Attachments	3-13
Determining the Weight of the Load	3-13
Understanding Workplace Conditions	3-14
Working in Hazardous Environments	3-14

4 Operating the B40i4 Forklift

Operator's Daily Inspection	4-1
Basic Operating Instructions	4-1
Getting On and Off the Forklift	4-2
Driving Position	4-2
Starting and Traveling	4-2
Turning	4-3
Stopping	4-3
Stopping Distance	4-3
Parking	4-3
Setting the Forks	4-3

Operator Controls and Indicators	4-4
Keyswitch	4-4
Drive Pedal	4-4
Stop Pedal	4-4
Direction Control Lever	4-5
Lift Lever	4-5
Tilt Lever	4-5
Side Shift Lever	4-5
Horn	4-5
Seat Switch	4-5
Seat Belt	4-5
Seat Adjustments	4-6
Steering Wheel	4-6
Steering Column	4-6
Dash Display	4-7
Fork Positioner, Non-Side Shifting	4-7
Precautions for LP Gas Engines	4-7
Liquefied Petroleum Gas (LPG)	4-7
LPG Tank Removal	4-7
Refilling an LPG Tank	4-8
Installing an LPG Tank	4-8
Engine Coolant	4-9
Handling a Load	4-9
Retrieving a Load	4-9
Transporting a Load	4-12
Traveling on Inclines	4-12
Unloading the Forklift	4-13
Fire Extinguisher Option	4-15
In Case of a Fire!	4-15
Bendi B40i4 Daily Operator Checks	5-1
Inspections Overview	5-1
Maintenance Schedule	5-1

Engine Compartment Access	5-1
Daily Checklist	5-1
Operator's Daily Checklist	5-2
Tires and Wheels	5-3
Parking Brake	5-3
Accelerator Control	5-3
Lift Chains	5-3
Forks	5-4
Electrical Fastener Connections	5-4
Hydraulic Cylinders, Fittings & Hoses	5-4
Hydraulic Oil	5-4
Operator Controls	5-4
Directional Control	5-5
Auxiliary Function Controls (Optional)	5-6
Horn	5-6
Lights and Alarm	5-6
Steering	5-6
Steer Column Tilt & Telescope	5-6
Dash Display	5-6
Seat, Belt, Slides & Switch	5-6
Major Structural Points	5-6
Safety Labels	5-6
Capacity/Identification Plate	5-6
 Unusual Noises	 5-7
 General Truck Lubrication	 5-7
 Recommended Lubricants	 5-7
 Technical Specifications	 5-9

Forklift Safety and Familiarity

Before You Begin (Please Read)

This chapter of the Bendi B40i4 Forklift Operator's Manual discusses important safety information regarding the operation and maintenance of your Forklift.

The safe and efficient operation of a lift truck requires a skilled and attentive operator.

To develop the skills required:

1. Receive training, pursuant to OSHA 1910.178(1) dated 12/98, in the proper operation of this forklift.
2. Understand the capabilities and limitations of the lift truck.
3. Become familiar with the construction of the lift truck and see that it is maintained in good condition.
4. Read and understand the warnings and operating procedures in this manual.

IMPORTANT

The Bendi Series* Model trucks have been designed for optimum safety of their operators. It is imperative that all operators follow the safety guidelines listed in this section and adhere to all Important, Caution, Warning and Danger notices found within this manual.

This chapter on Safety must be carefully read, understood and adhered to strictly by all operators and service personnel operating and/or maintaining the Bendi Series Model lift trucks.

DO NOT use this truck until you have thoroughly read this manual.



DANGER

Failure to comply may cause risk of death or serious injury to yourself and others.

**Landoll and the Bendi Series are trademarks of the Landoll Corporation. All other brand and product names are the trademarks of their respective holders.*

Landoll Corporation, Bendi Series trucks meet or exceed ASME B56.1-Part III, Safety/Powered Industrial Trucks.

IMPORTANT

NO modifications or additions may be made to this forklift without prior written permission from:

Landoll Corporation
Material Handling Product Group
1900 North Street
Marysville, KS 66508 U.S.A.

Telephone: (785) 562-5381

Fax: (785) 562-4853



WARNING

- Do not make modifications or additions to electrical devices.
- Do not tamper with or disconnect safety features or modify protective guards, such as overhead guards or load backrest extensions.
- Do not add or remove structural components.
- Any changes could effect truck capacity or safe operation of the truck and is a serious safety violation, that could cause personal injury or weaken the trucks construction.

Site Supervision

Supervision is an essential element in the safe operation of powered industrial forklifts. The site supervisor is to check that the Operator's Manual is in the seat compartment on the forklift at all times.

Operators must be trained on the use, maintenance and safety aspects of the Bendi B40i4 Model trucks, under the supervision of a trained and experienced operator. Only those individuals trained to operate and/or service this truck may do so. Familiarization and driving practice with a new truck should be arranged in a safe area, away from other forklifts, obstacles and people. The training program must be applied to all new operators, regardless of previous experience. Operator performance must be evaluated to ensure he/she has the proper skills and knowledge to operate the truck.

Operators must be retrained when new equipment is introduced, existing equipment is modified, operating conditions change or an operator's performance is determined unsatisfactory.

The truck is to be inspected daily for problems or damage which may risk the driver's safety and any people in the work area, or possible damage to the truck and the load being moved.

When trucks are used on a round-the-clock basis, they must be inspected after each shift.

Problems found must be reported and corrected. The truck is to be taken out of operation until all repairs have been made and the truck has been re-inspected for safety.

IMPORTANT

Anytime you are doing maintenance or repair on the Landoll B40i4 truck, unless the truck must be on for investigative testing, remove the key from the key switch console. Remove the main power fuse or connector and install a commercially available Lock Out/Tag Out device at the battery connectors, because it's possible to have a duplicate key. Also, install a lockout warning reminder on the steering wheel warning that the truck is not available for use.

Terminology and Illustrations Used in Manual

Whenever front and rear, right and left are mentioned throughout this manual, it is assumed that you are seated in the vehicle looking toward the forks.

This manual makes use of many pictures and illustrations to help you to locate components on your B40i4 forklift and allow you to follow instructions/procedures.

You will notice that most illustrations have an identifying Figure number below the illustration frame. As an example ... "Figure 1-1."

Understanding Safety Statements

You will find various types of safety information on the following pages and on the machine decals (signs) attached to the vehicle. This section explains their meaning. The Safety Alert Symbol means ATTENTION! YOUR SAFETY IS INVOLVED!

NOTICE
Special notices - Read and understand thoroughly.

 CAUTION
Proceed with caution. Failure to heed caution may cause injury to person and/or damage product.

 WARNING
Proceed with caution. Failure to heed warning <u>will</u> cause injury to person and/or damage product.

 DANGER
Proceed with extreme caution. Failure to heed notice will cause injury or death to the person and/or damage product.

NOTE

You should read and understand the information contained in this manual and on the machine decals before you attempt to operate or maintain this forklift.

B40i4 Decals and Placement

The location of each machine sign on the Bendi B40i4 forklift is illustrated on the next page. See Figure 1-1 on page 3 and a list of each machine decal is on the following page, See Figure 1-2 on page 1-4.

Make sure you check each machine sign before you operate your B40i4 forklift and replace any that are no longer legible, are missing or damaged.

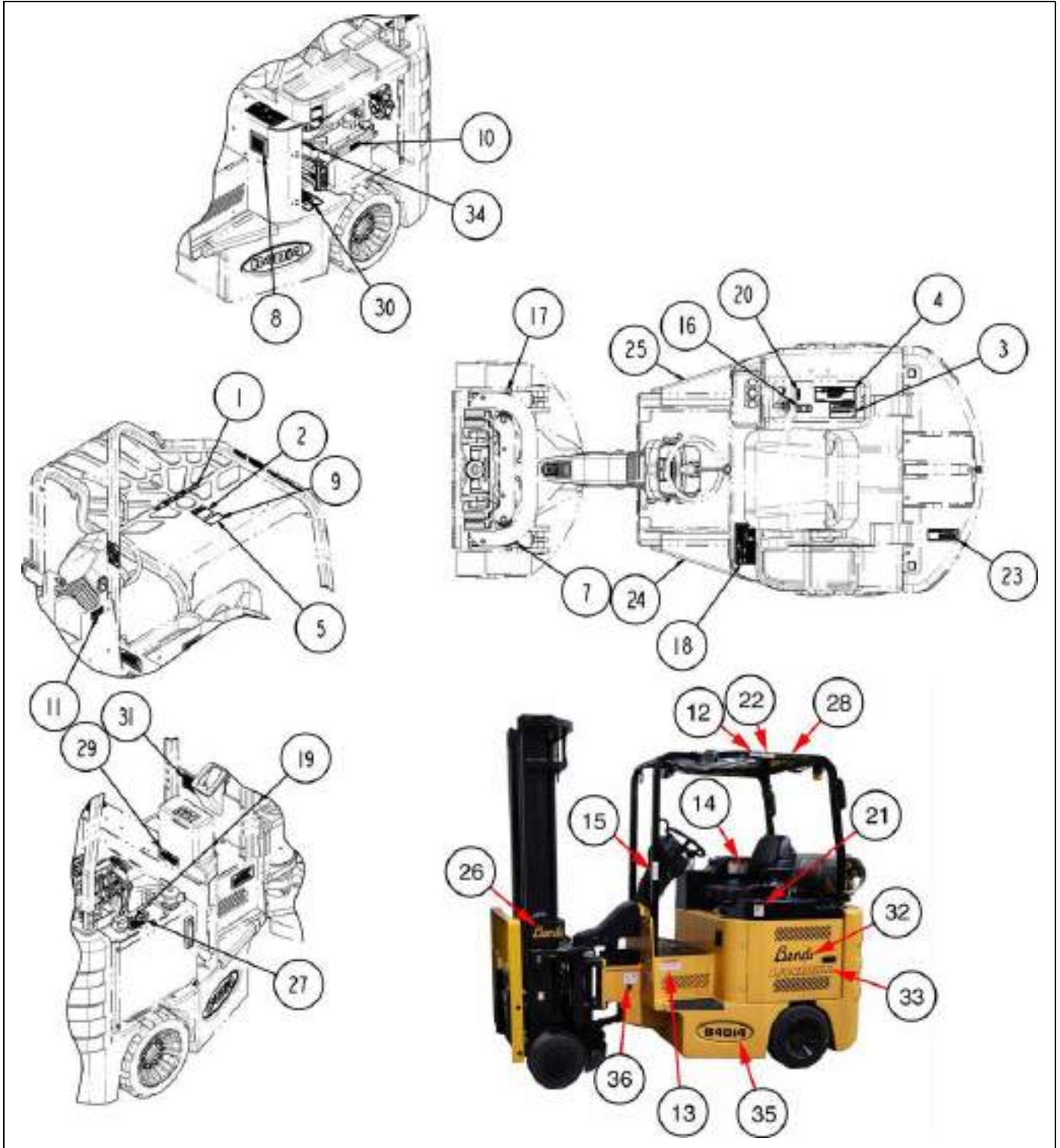

Figure 1-1: Bendi B40i4 Forklift Decal Placement

Operator Safety



WARNING

- Check that all directional controls are in their **NEUTRAL** position and your seat belt is fastened before setting the Keyswitch to **ON**, see “Seat Belt” on page 1-6.
- Be extremely careful that **NO** part of your body (head, feet, arms, legs, fingers) is outside the operator’s compartment, subject to injury by aisle supports, other trucks or any obstacle in the area.
- Always keep loose clothing, jewelry and hair out of the restricted areas (especially pinch areas), as labeled on the truck.
- Know the location of and be especially careful of all pinch points, as indicated by the **WARNING** and **DANGER** labels on the truck. Be especially careful when there are other people, moving or fixed objects in the working area, or when the load reduces visibility. See “Visibility” on page 1-8.
- Never drive a truck close to anyone standing in front of an object. Ensure that people stand clear of the rear swing area before making turns.
- **NEVER** lift, lower or transport people.
- **NEVER** allow anyone on or under the forks (or load).
- Under no circumstances are there to be any riders anywhere on the forklift, other than the operator.
- When driving in narrow aisles, make sure there is enough space for the truck and the load, travel at reduced speeds, and where applicable, request a helper to guide you safely through the area.

- The operator is responsible for observing all instructions and regulations in his/her daily work routine, related to the use of this truck.
- Be careful at cross aisles, doorways and other locations where people may step into the path of a moving truck.
- The operator must check the condition of the truck at the start of each work shift. Check the operation of the steering and stopping; The direction control lever; The shift, tilt and lift/lower controls; The condition of the parking brake, horn and signaling devices, where applicable.
- Make sure all access/service panels, doors and covers are installed, closed and latched tight. Do not operate the truck with panels, doors and covers removed, opened or unlatched.
- Keep the truck clean and in good working order. Report any problems or damage that may risk the safety of the driver or any people in the work area. Problems found must be reported and corrected. The truck must be taken out of operation until all repairs have been made and the truck has been reinspected for safety.
- Always start, stop, change direction, travel and stop smoothly, so as not to shift the load and/or overturn the truck.
- Do not indulge in stunt driving or horseplay.
- Drive carefully and slowly onto dock boards and bridge plates. Do not exceed the rated capacity of the dock boards or bridge plates and ensure dock boards or bridge plates are properly secured, either by being anchored or by being equipped with devices that will prevent slipping.
- Check that dock boards have substantial contact with both the dock and the carrier, preventing them from rocking or sliding.
- Maintain a safe distance from the edge of ramps, platforms and other similar working surfaces.
- When leaving the operator’s compartment, the forks must be lowered to the floor, the mast must be placed in a vertical position, all controls must be in a **NEUTRAL** position, and the key switch must be set to the **OFF** position. Truck wheels must be blocked if the truck is parked on an incline.

NOTE

A powered industrial truck is considered unattended whenever the operator leaves the truck and it is not in view or when the operator is 25 feet (7.6m) or more away from the truck.

NOTICE

In the interest of operator safety and in compliance with OSHA regulations, guidelines have been developed for performing service and maintenance on the truck.

Before performing service and maintenance on the truck, review the following sections in this manual for additional procedures to be followed.

Lock Out/Tag Out

IMPORTANT

When performing maintenance or repair on the Bendi B40i4 truck, unless the truck must be running for testing, remove the key from the key switch. In addition, because it's possible to have a duplicate key, install a commercially available Lock Out/Tag Out device on the truck. Also, install a lockout warning reminder on the steering wheel warning that the truck is not available for use.

Operator Safety Training

DANGER

Every forklift operator must be trained in accordance to the rules provided by appropriate legislation. Your employer is to ensure that each powered industrial truck operator is competent to operate a powered industrial forklift safely, as demonstrated by the successful completion of the relevant training course. Operating a powered industrial truck without the proper training can cause serious injury or death.

Before you start using the B40i4 forklift you must become familiar with its capabilities. Thoroughly read and understand the material contained in this Operator's Manual and the various machine signs (decals) found on your vehicle. Whether you are a new operator or have used forklifts for many years, read through this Operator's Manual. It provides step-by-step instructions to help you operate the Bendi B40i4 forklift in a safe and efficient manner.

Seat Belt

The drivers seat belt must always be worn when driving the forklift. Sit up straight in the driver's seat. The lap restraint must be worn low and snug on the hips, just touching the thighs and must not be twisted.



WARNING

A twisted belt has the potential to cause serious injury. In a crash or a tip-over, the full width of the belt would not be available to take up the impact forces.

IMPORTANT

Make sure the release button on the buckle is positioned so you can unbuckle the seat belt quickly in case of an emergency.

Seat Safety Switch

A seat switch tells the vehicle controllers when a driver is in the operator's seat. Traction operations will shut down if the seat switch opens, signaling that a driver is not in the operator's seat.

NOTE

A two to three second delay is programmed into the seat switch to avoid nuisance shutdown and interruption of normal operations.

Parking Brake

The parking brake is located on the left stop pedal, from the operator's seat, and is engaged into place with your foot using the levers on the side of the pedal. Pushing to the bottom and left will set the park brake, and more force put in the upper left to disengage it. It includes a safety interlock that shuts down the drives, disables the direction control lever and applies the brakes to prevent further truck movement. To continue, you must set the direction lever to NEUTRAL, release the parking brake, and then set the lever to the desired direction. See Figure 1-3.

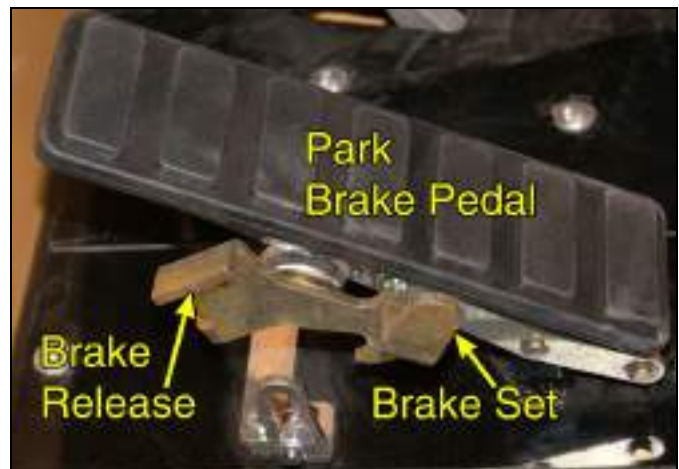

Figure 1-3: Park Brake Mechanism

Tipping Hazards and Conditions



DANGER

- Lift truck tip-over can cause serious injury or death to the operator or others in the area. Every operator must be thoroughly familiar with the tipping hazards listed in this section and must always avoid any operation of the truck which is likely to result in tipping.
- All forklifts that elevate and tilt loads are subject to the risk of tipping over, especially when accelerating or stopping abruptly.
- Transporting loads off-center also increases the risk of tip-over.

If a tip-over occurs, the operator should follow these guidelines:

- Do not jump.
- Brace your feet firmly.
- Hold on tight.
- Lean away from the tip.

The most common causes of tip-over are listed in this section. However, the operator must use good judgment based on proper training and experience to determine turning sharpness and speed for the load being handled and the operating surface (or road) conditions.

A truck can tip longitudinally (tipping over the front or rear wheels) or laterally (tipping either to the left or right side).

Longitudinal Tipping Can Occur When:

- the forklift is overloaded. See Figure 1-4.
- the mast is tilted forward excessively, with or without a load.
- the load is raised and you stop suddenly while the truck is traveling forward or backward.
- the load is raised and the truck is accelerated while it is traveling forward or backward.
- the truck is driven forward down a steep incline with a load.
- the forklift is driven backward up a steep incline with a load.

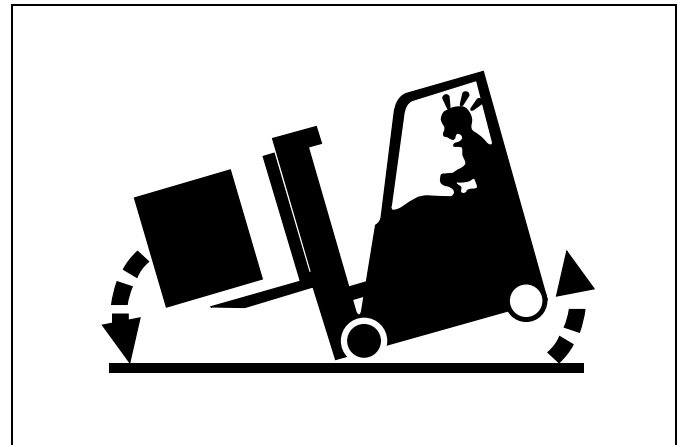

Figure 1-4: Longitudinal Tip

Lateral Tipping

Lateral Tipping Can Occur When:

- the truck is turned sharply while traveling rapidly in either direction, with or without a load. An unloaded truck can tip easier than a loaded truck (with the load lowered). See Figure 1-5.
- the load is raised and the truck is being turned while traveling in either direction.
- the load is raised and the truck is being turned and accelerating or braking while traveling forward or backward.
- the truck is turned while traveling on a ramp or other inclined surface.
- a load heavier than the rated truck capacity is lifted.

Tipping over in these conditions is made more likely by overloading, excessive mast tilt, or off-center positioning of the load.

Soft tires can also reduce stability. The truck is equipped with tires of a size and hardness that will provide the necessary traction and maintain a proper shape to minimize tipping. Always replace tires with the type originally supplied by the manufacturer.

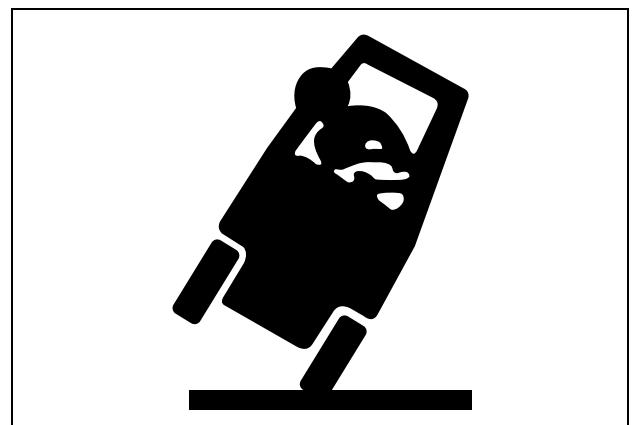

Figure 1-5: Lateral Tip

Longitudinal or Lateral Tipping

The Truck Can Be tipped Either Longitudinally or Laterally when driving:

- over objects on the floor or ground.
- off the edge of a paved surface.
- into a pothole in a paved surface.
- off the edge of a loading dock, or off the edge of a loading ramp. (It is important to avoid driving too close to the edge of a dock or ramp).

When loading or unloading a highway truck or trailer, make sure the highway truck can not move away from a dock while loading is in process. Make sure the highway truck or trailer has its brakes applied, key switch turned OFF, and if on an incline, has the wheels blocked.

Tipping can also occur if the forklift collides with another truck or other vehicle, or if the mast runs into an overhead obstruction.

Traveling and Load Handling

- Observe all traffic regulations. Keep to the right and maintain a safe distance from the truck ahead based on speed of travel. Keep the truck under control at all times.
- Yield the right of way to other people in the area.
- Slow down and sound the horn at cross aisles and other locations where visibility is obstructed.
- Keep a clear view of the path of travel and be alert for other traffic, people and safe clearances.
- Under all travel conditions, operate the truck at a speed that permits you to bring the truck to a complete stop in a safe manner.
- Do not handle unstable loads. Use care when tilting forward or backward, stacking, returning or retrieving a load.
- Never travel with the mast tilted forward.
- Never exceed the truck's maximum lifting capacity. Refer to "Technical Specifications" on page 5-9 and the identification plate located right and front of the seat. See Figure 3-2 on page 3-3.
- The Identification plate lists the load weights allowable for various fork heights, the truck model number, serial number and other basic truck data.
- Pay particular attention when picking up a new load to ensure the load weight and height requirements are within the truck's capacity. Truck stability and handling may be adversely affected.
- Do not transport loads or other items within the operator's compartment or other areas of the truck.
- Check that the load is properly positioned on the forks before lifting.

- Spread forks as far apart as the load permits and push completely under the load. Check that forks and loads are centered. Use care when handling off-center loads.
- Travel with the mast tilted backward.
- Travel with forks or load in recommended traveling position, with the forks/load 8" to 12" above the floor.
- Elevate mast or load only to pick up or deposit a load.
- Watch out for obstructions, especially overhead.
- Watch all clearances.
- Tilt a loaded mast slowly.
- Do not release the lift/tilt controls suddenly when lowering loads. This may cause bouncing of the carriage, which could dump the load.
- Do not allow anyone, under any circumstances, to walk or stand under the forks or any part of the load.
- Never place any part of your body between the mast structures or any moving part of the truck.
- Do not turn when traveling on ramps. When descending ramps, travel forward (forks facing downhill) when empty, travel backward (forks facing uphill) when carrying a load.
- Use care even when traveling without a load. Avoid high speeds, sharp turns and abrupt stops.

Speed

Travel speed must be chosen according to the situation, such as the load being handled, road surface conditions, visibility, people working in the area, moving and fixed objects in the area, and cross aisles. Always operate the truck at a speed that will permit it to be brought to a stop in a safe manner.



WARNING

Careless driving, including, fast starts or abrupt stops, excessive speed at turns or through cross aisles or hard turns at high speeds can all lead to serious personal injury and damage to the truck or load. Always drive with safety as your number one goal.

Visibility

Where visibility is restricted, travel at very slow speed and use the horn frequently.

Always ask for a helper ("Banksman") to guide you safely through the area when visibility is restricted.

Always rotate in the driver's seat to face in the direction you are traveling.

Gas Engine

The Bendi B40i4 Model truck is powered by a liquefied petroleum gas (LPG) engine and is designed to minimize harmful emissions. Fuel is supplied from a standard 33 or 43 lb. ICC gas cylinder tank mounted horizontally on the rear deck of the truck. The tank is held in the tank mount plate attached to the truck using a strap and latch. See Figure 3-5 on page 3-5. An ultrasonic fuel level sensor is mounted to the back mount plate. This sensor provides the operator with an accurate quantity of fuel left through the dash display. The engine muffler is equipped with baffles to block the ejection of sparks or flame, and meets standards required by the Forest Service of the U.S. Department on Agriculture.



DANGER

Do not smoke, use and open flame, or create arcs or sparks near the LPG propane tank. Gas is very flammable and can cause the canister to explode, causing serious injury or death.

Engine Care

The gas engine should be maintained per manufacturer's requirements. This includes regular oil changes, checking and replacement of belts and filters, checking coolant levels, and checking engine compression. Refer to the Service Manual for more specific information concerning proper maintenance and care of engine.

Service/Maintenance Safety

When it becomes necessary to do any service repair or maintenance to the truck, it is important to first review the following safety guidelines.



WARNING

You could be injured and the forklift could be damaged if you try to do service work without proper training or equipment.

1. Be sure you have sufficient knowledge, experience, the proper tools and replacement parts before you attempt any truck maintenance.
2. Be sure to use proper nuts, bolts and other fasteners. Many are specifically rated; that is, SAE Grade 5, SAE Grade 8, ISO Prop Class 8.8, etc., and must be replaced with the identical type. It is recommended to use only Landoll authorized replacement parts.



WARNING

If you use the wrong nuts, bolts or other fasteners, parts will later break, stretch or loosen. Serious injury could occur.

3. Whenever possible, return the truck to a service area having sufficient lighting, work space and an assortment of tools needed to complete the service.
4. Set the Keyswitch to OFF and set the direction control lever to NEUTRAL.
5. Perform the Lock Out/Tag Out procedure.
6. Make sure all lifting devices and supports, such as, a support or jack stand, are capable of handling the weight of the load being applied.



WARNING

- **To be certain the truck will not move, place wedges (or blocks of wood) at the front and back of the tires.**
- **If you are servicing the bearings or tires, place the blocks at the front and rear of the tires farthest away from the one being serviced. (The tire on the opposite side of the truck and at the opposite end.)**

7. Always place an appropriate support stand under the truck if it is being lifted, then lower the truck on to the stand, having both the lifting device and stand supporting the weight of the truck.



DANGER

Getting under a truck when it is lifted or jacked is dangerous and could cause serious injury or death. Never go under a truck that is supported by only a jack.

8. Fully open the required truck covers and be sure they are braced to prevent accidental closing.

Receiving and Inspection

This Chapter of your Bendi B40i4 Forklift Operator's Manual covers all of the procedures and information you will need to successfully receive your truck and prepare it for operation. Storage, Towing and Shipping information for the forklift is also provided,

Before shipping from the Landoll Corporation, each Bendi B40i4 truck is inspected to make sure the truck you receive is in impeccable condition and equipped per your order.

Additionally, we recommend that you:

- Inspect the truck for any signs of physical damage during shipment. Note any apparent damage on the bill of lading and request the delivery agent sign it.
- Report any damage, if any, to your distributor and the shipping company.
- Verify that the truck configuration and options match your purchase order. Report any inaccuracies to your distributor.

Items Furnished with Your Truck

Bendi B40i4 trucks are shipped from the factory with one copy each of the Operator's Manual, Parts Manual and a set of ignition keys attached to the steering column. No additional items are required to operate the truck.

Tools and Test Equipment

In general, no special tools or test equipment beyond those found in a well-equipped service center are required for general maintenance by the operator. However, custom bearing, seal installation tools and a calibrated torque wrench are helpful when performing more involved service.

Preparing the Forklift

1. Check the hydraulic oil level. See "Hydraulic Oil" on page 5-4.
2. Check the engine oil level. (See "Checking the Oil Level," in the Service Manual). Raise the engine compartment cover.

Inspecting the Forklift

Before releasing the truck for use, prepare a log book or log sheet for each truck at your site. List all services, repairs and adjustments performed, as well as equipment or operation problems, along with when they are repaired (hour meter reading and date).

Permanent logs serve as a checklist to show maintenance and repair history, and to record whether faults have been corrected.

NOTE

Chapter 5 contains "Bendi B40i4 Daily Operator Checks" on page 5-1, which should be used as a guideline when inspecting the truck.

Visual Inspection

Many problems can be spotted by a simple visual inspection of the truck; such as, oil leaks, damaged tires, cracks in welds or forks, damaged covers, etc.

It is possible for dirt, grease, oil and debris to mask some problems. If possible, the truck should be cleaned on a regular basis. If possible, high-pressure washing should be avoided.



DANGER

Grease solvents are often toxic and may be flammable. Use only in accordance with the solvent manufacturer's recommendations supplied with the solvent. For example, use only in a well-ventilated area and do not breathe vapors. Wear protective goggles, aprons, and gloves. Avoid contact with skin, eyes and clothes. Keep away from heat and flame.

Do not smoke when using solvents or in the area where solvents are stored.

Failure to observe these precautions may result in death or injury.

Lubricate all grease fittings and metal-to-metal surfaces located outside the truck. Refer to "Rotation Bearing Grease Points" on page 5-7 for lubrication information.

General System Checks

With the truck Keyswitch set to OFF and the direction control switch set to NEUTRAL, perform a walk-around inspection. Always pay strict attention to all CAUTION, WARNING, and DANGER decals affixed to the truck and thoroughly read the SAFETY chapter of this manual. Check for obvious damage that would require more detailed inspection.

If you notice a problem, immediately report it to your supervisor, record it in the truck log book and have it checked or repaired before releasing the truck for use.

Driver's Seat

- Check the seat covering and seat belt for rips or cuts.
- Check that the seat belt is firmly attached and that the buckle is not damaged.
- Check that the seat belt works properly.

The driver's seat switch system includes an interlock that shuts down the drive and disables the direction control (resets to NEUTRAL and requires you change the direction lever again to establish direction) bringing the truck to a smooth STOP.

The mast functions remain operable.

To check the seat switch interlock:

1. Sit in the driver's seat and start the engine.
2. Set the direction control lever to FORWARD and slowly depress the drive pedal until the truck begins to move.
3. Lift yourself from the seat far enough to release the seat switch.
4. Press the drive pedal and notice you must return the direction switch to neutral and then back to forward (or backward) for motion control to return. If this is not observed, immediately report this to your supervisor and record it in the truck log book. Have this operation checked and repaired before releasing the truck to use.

Fasteners

Check for damaged, loose or missing screws, bolts and nuts. Tighten and/or have service replace as needed.

Horn, Lights, Etc.

Check lights for proper on/off operation and for blown bulbs. Check that the horn sounds when pressed. Repair and/or replace as needed.

Hydraulic Lines and Loose Fittings

Check underneath the truck for evidence of fluid leaks. Look for hydraulic hose wear, damage and leaks.

Make sure clamps and fittings are tight. If leaks are found, have maintenance repair all leaks immediately and check the hydraulic fluid level. Do not use the truck.

Hydraulic Oil Level

Check the oil level weekly. Low oil can cause operational problems. See "Hydraulic Oil" on page 5-4.

Dash Display

Inspect the dash display for errors, faults and damage to ensure normal operation.

Stopping

With the engine running, drive forward slowly and then release the drive pedal. The truck should stop smoothly without noticeable side pull or vibration.

Mast Operation

With the engine running, raise the mast. Check that the primary cylinder extends fully and that the lift carriage rises to the top of the inner rails before the secondary cylinders begin to move.



WARNING

Never place your head, hands, arms or feet in the mast area. Make sure there is sufficient room above to raise the mast safely.

- When the lift carriage reaches the top of the inner rails, the secondary cylinders and middle rails begin lifting. Check to make sure the rails travel smoothly and that there is no chatter or visible binding.
- With the mast fully extended, begin lowering the mast. The secondary cylinders and middle rails fully lower first, followed by the primary cylinder and the lift carriage. Check for smooth travel with no chattering or visible binding.

- If there is noticeable chatter or binding, immediately notify your supervisor or service personnel.
- DO NOT attempt to repair the mast or operate the forklift until the problem is corrected.

**DANGER**

If the mast does not raise or lower properly, or shows signs of binding, it may release or stop suddenly. Sudden motion may allow the load or carriage to drop, this could result in death or serious injury to the operator or nearby persons, and/or damage the load.

Overhead Guard

Check the overhead guard and make sure that it is firmly attached to the truck and that all fasteners are secured. The overhead guard is adjustable to accommodate various drivers' and operating restrictions (low ceilings, door openings, etc).

Parking Brake

The parking brake system is controlled by a lever connected to the left side of the stop pedal.

To check the park brake:

- Step on the back of the lever down to set it. Step on the top of the lever to release it. You cannot drive your Bendi forklift while the brake is engaged. The truck will not respond to the drive pedal unless the lever is released.
- If the park brake does not stop (hold) the forklift, the truck must be removed from operation until the problem has been identified and corrected.

Rust or Corrosion

Check the truck frame, side and floor panels for rust and corrosion. Clean rusty or corroded areas and repaint, if applicable. Apply a thin coat of oil to any bare metal surface.

Safety Decals, Data Plates, etc.

Check for damage and missing decals or data plate. Check that the decals are legible. Clean and/or replace as needed.

Tires and Wheels

Check tires for cuts or chunking, oil slicks, embedded foreign material or excessive wear. Check wheels for missing lug nuts. Repair and/or have service replace immediately. Do not use the truck.

Welds, Cracked or Broken

Check for damage and reliability of welds. Clean and repair immediately. Do not use the truck.

Wires or Connectors

Look for damaged, cracked or broken insulation, bare wires showing loose or broken connectors. If electrical problems are found, have service make repairs immediately. Do not use the truck.

Fire Extinguisher Option

If your truck includes a fire extinguisher it should be inspected at least monthly, or more frequently if circumstances dictate.

The extinguisher should be checked to see that:

- it is not damaged.
- the discharge outlet is not blocked.
- it is fully charged and the seal is not broken.
- the instruction pamphlet is clearly visible.

IMPORTANT

Dry-powder extinguishers are shipped fully charged. Do not experiment with your extinguisher since even a small amount of discharge could cause it to slowly lose the rest of its pressure, rendering the extinguisher useless.

Replacing the Battery

The following are steps that must be taken when the battery is in need of replacing.

1. Return the truck to your service area.
2. Set the key switch to OFF and place key in a safe place.
3. Place blocks in front of and behind all wheels.
4. Unlatch the compartment cover (below drivers seat) and raise the engine compartment top cover.
5. Secure the cover to the overhead guard latch and insert the locking pin. Shake the cover to be sure latch is secured.
6. Open the left side door by sliding the locking level to the right, and the swing the door fully open.

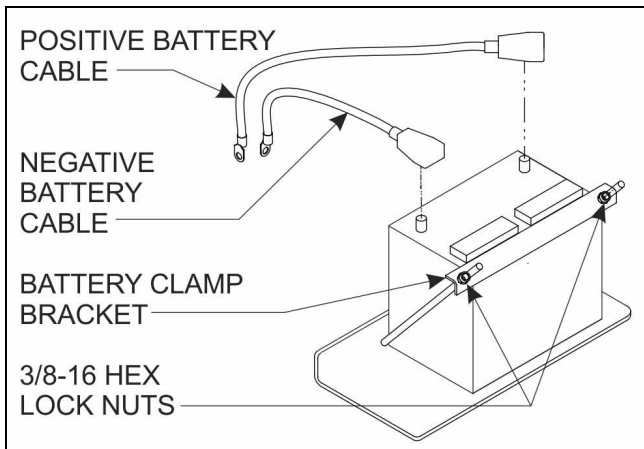

Figure 2-1: Battery Disconnects

- If the truck must be stored outside, it must be covered securely with a tarp, or other water-resistant material. Continued exposure to sunlight will cause deterioration of rubber tires, gaskets and hoses, as well as vinyl seat coverings, etc.

Towing the Truck

If the truck breaks down and cannot be repaired at that location, it may be towed by attaching a suitable hook and chain to the tow pin in the rear of the truck. See Figure 2-2. Remember with no power to the truck being towed, steering will be difficult. Carefully and slowly tow the truck backwards to your service repair area.

An operator must be on the towed truck, wearing a seat belt.



DANGER

Be certain there are no loose wires or tools that could bridge the two battery terminals. If conductive material connects the two terminals arc flash, severe burns, or death may occur.

7. Disconnect the negative cable (black) first, then the positive (red) and lay the cables to the side.
8. Undo the 2 - 3/8 - 16 hex lock nuts and remove battery clamp bracket. The batter should be free to move.
9. When installing the new battery, it must be pushed up against the tray weldment and centered.
10. Connect the positive battery cable (red) to the positive terminal on the new battery and the negative battery cable (black) to the negative terminal on the new battery.



WARNING

- Make sure the towing equipment is capable of handling the weight of the truck being towed.
- Never lift a truck using straps, chains or hoists of any type.
- Never connect lifting equipment to the operator's compartment overhead guards.
- Never use the truck to tow materials.
- Never tow a truck that is carrying a load.
- Never connect towing equipment to the mast.
- For better traction, partially load the truck doing the towing.

Storage, Towing or Shipping

Truck Storage

If the forklift is to be stored for a length of time:

- The truck should be stored indoors within a temperature range of +35° F (2° C) to +115° F (46° C) and a relative humidity of 90%, preferably less.
- The truck should be raised with the tires at least 2" (51 mm) off the floor and the frame set on large wooden blocks. Hard polyurethane tires, over long periods of time can develop flat spots that may not return to normal when the truck is returned to service, rendering the tires defective.



Figure 2-2: Tow Pin

Bendi B40i4 Forklift towing instructions:

1. With ignition off and park brake pedal released locate the brake release pump/valve assembly and towing instructions inside the left side engine compartment access door. See Figure 2-3.



Figure 2-3: Brake Release Pump/Valve Assembly

2. Close the manual valve by pulling upward on the black handle, rotating 90°, then lowering until you feel a click.
3. Push and release red manual hand pump approximately 5 to 7 times to build enough pressure to release the park brakes.

NOTE

The B40i4 forklift may be towed a maximum distance of 200 yards at a maximum of 2 mph.

4. To reset park brakes, open the manual valve by pulling upward on the black handle, rotating another 90°, and lowering until you feel the detente cross pin settle into place again.



WARNING

Failure to reset park brakes will result in the forklift having no brake function at all.

Shipping the Forklift

1. Set the mast to its forward position (straight ahead).
2. Back the truck onto its carrier so that the forks are pointed away from the forward direction of motion.
3. Set the mast to its forward (level) position and lower the forks to the bottom of the mast. Align the mast indicator pointer located on each side of the mast to a level position, as viewed from the front of the truck.
4. Set wedges against the front and rear tires and fasten them to the floor of the carrier. If the carrier is equipped with rings or receptacles for chains or cable rope, support the truck as firmly as possible.

IMPORTANT

Do not run chain or wire directly touching any finished metal surface. Use padding as necessary to protect the truck finish from chains or cables.

Understanding the Bendi B40i4 Forklift

This Chapter of your Bendi B40i4 Forklift Operator's Manual contains information that will familiarize you with the basic forklift design and operating principles.

Vehicle Description

The Bendi B40i4 is a narrow aisle type lift truck. The principle operation of this forklift truck is that the weight of the load, which is carried on the forks in front of the load wheels, is offset by the combined weight of the heavy truck chassis and its engine. To maintain a safe counterbalance limit, a ballast weight is also mounted to the rear of the truck chassis.

The Bendi B40i4 forklift is available in a maximum 4,000lb. capacity. The front end can be pivoted 180 degrees. This permits the vehicle to act as a conventional as well as a narrow aisle forklift. The Bendi B40i4 truck also offers:

- Four-wheel configuration - front load wheels and articulation; dual rear drive/braking wheels.
- Interactive Dash Display.
- Hydraulic lever operation for load functions - utilizing a three-function hydraulic control valve.
- 12 volt DC battery.
- Triplex or Quadplex high visibility mast configurations.
- Lift capacity is a maximum of 4,000 lbs./1,814kgs. at 24"/600 mm load center.
- Ergonomically designed operator compartment includes sit-down operator position, adjustable driver's seat, tilt/telescoping steering wheel, hand lever direction and mast controls, arm rest and operator supply tray.
- Safety interlocks - Keyswitch activation and operator seat safety switch, plus an electrical lockout requiring the direction control lever to be in the neutral, or center position, before power can be restored.

Machine model, serial and option numbers (where applicable) are stamped on the identification (capacity) nameplate affixed near the front operator's cab. See Figure 3-1.

IMPORTANT

- **Bendi B40i4 truck operators and service personnel must familiarize themselves with this manual and the Bendi B40i4 truck to provide safe and efficient operation. Practice runs in a controlled and safe area, away from obstacles and other personnel, are recommended. Unauthorized driving by untrained or unskilled personnel must be strictly prohibited.**
- **All safety notices in this manual and the safety regulations, or standards valid in your local area, must be strictly enforced.**

Truck Identification

The following illustration will help you locate components on your Bendi B40i4 forklift.

1. Forks
2. Load Backrest
3. Mast
4. Rear Drive Wheels
5. Steer/Load Wheels
6. Overhead Guard
7. Steering Column, wheel and knob
8. Drive and Stop Pedals
9. Dash Display
10. Engine Compartment
11. Identification Plate
12. LPG Tank
13. Mast ID Number Location
14. Operators Controls



Figure 3-1: Component Locations

Identification Plate

The identification plate, which lists the rated capacity, serial number and other vehicle characteristics. See Figure 3-2. It is located to the **left** of the seat. See Figure 3-1.

The following list explains items that appear on the identification plate:

- **Model** - The model number of your Bendi B40i4 forklift appears here.
- **Serial Number** - The serial number of your Bendi B40i4 forklift appears here.
- **Mast Number** - The serial number of the mast appears here.
- **Rated capacity** - The rated capacity is stated with the forks at various fork heights. As you lift the load higher, the rated capacity of the forklift decreases.
- **Lift height** - This is the fork height stated in inches and centimeters. This is the distance between the ground and the top edge of the forks.
- **Weight** - The rated capacity of the forklift at various fork heights. Rated capacity stated in pounds and kilograms.
- **Unladen Mass Without Battery** - Total truck weight.
- **Min Service Weight of Battery** - Not Applicable.
- **Max Service Weight of Battery** - Not Applicable.
- **Maximum Unladen Mass** - Total truck weight.
- **Battery Type** - Not Applicable.
- **Truck Type** - This designation assigned by the Underwriter's Laboratory (UL), Standard 558, describes the overall design of the components for the internal combustion engine powered truck. Type "LP" designated units are liquefied petroleum gas units having minimum acceptable safeguards against inherent fire hazards. Type "LPS" designated units are similar to the "LP" units with additional safeguards to the exhaust, fuel, and electrical systems.
- **Nominal Voltage** - Nominal voltage indicates that the truck uses a 12 VDC battery.
- **Horizontal Load Center** - The horizontal load center is equal to one-half the length of the rated load when the weight is evenly distributed.
- **Vertical Load Center** - The vertical load center is equal to one-half the height of the rated load when the weight is evenly distributed.

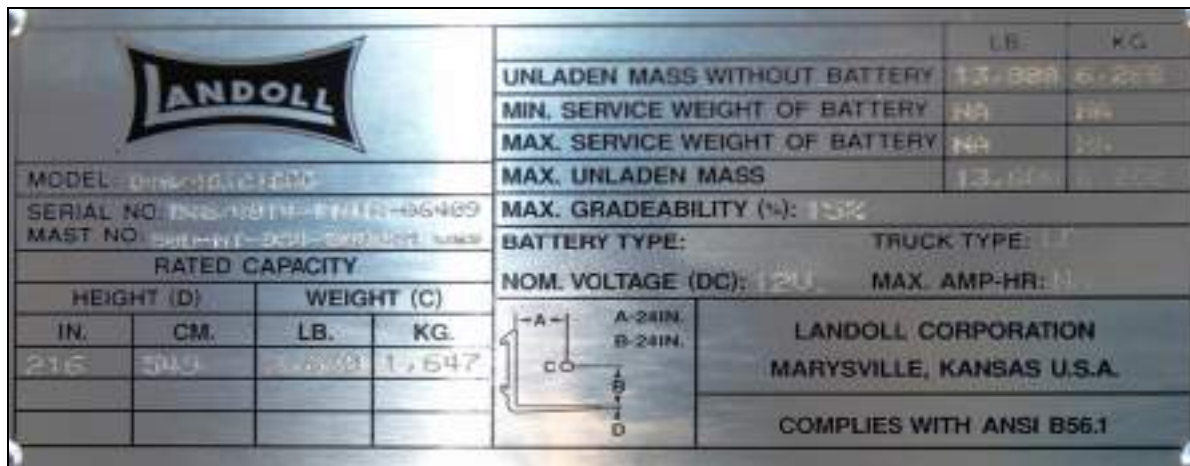

Figure 3-2: Identification (Capacity) Plate

⚠ CAUTION

The frame number is also located on the left side of the frame. You must compare the frame number listed on the identification plate with the frame number on the frame of the truck before you operate the truck.

⚠ CAUTION

The mast serial number is located on the left side of the mast. See Figure 3-3. You must compare the mast serial number listed on the identification plate with the mast serial number on the mast of the truck before you operate the truck.

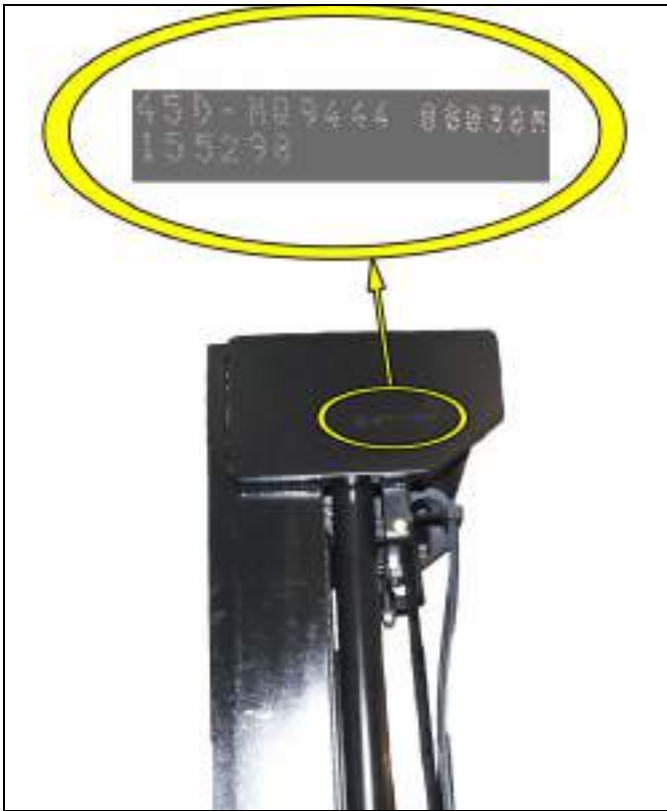

Figure 3-3: Mast Serial Number



Figure 3-4: Frame Serial Number

Bendi B40i4 Mast and Frame

The serial number for the Mast can usually be found towards the top as shown in See Figure3-3. It can best be viewed at an angle to the surface that it is stamped into. There is some location discrepancy because many masts can be installed onto the Bendi.

The serial number for the Frame of the B40i4 is found on the left side of the frame near the steering rotation point.

Bendi B40i4 Serial Number Code

The following information will help decode the forklift serial number:

[Baa/wwtt-yymms-xxxxx](#)

Table 3-1: Serial Number Code

aa	= 40 for 4,000 lb rated capacity truck
ww	= 44 for 44" frame width
tt	= type i.e. T4
yy	= last digits of year of manufacture (ex. "09 means 2009, "10" means 2010)
mm	= month of manufacture
s	component series; such as "A"
xxxxx	= frame number

Understanding Truck Rate Capacity

DANGER

Never load a lift truck beyond its rated capacity. Loading beyond rated capacities can cause axles to break, the truck to tip over, load to fall, serious injury or death. See identification (capacity) plate for rated capacity and load center information.

Before you begin to operate the Bendi B40i4 forklift, you need to know some basic operation principles. One of the most important facts about the Bendi B40i4 forklift is its rated capacity (how much weight it can safely lift) and how to properly carry a load to maintain stability. This weight is listed as the rated capacity on the identification plate. See Figure 3-2.

The rated capacity varies for each load depending on:

- Where the horizontal and vertical load centers are.
- The height you plan to lift the load.
- Attachments used.

Truck Overview

Before operating the Bendi B40i4 Forklift, familiarize yourself with the basic parts of the truck. The following sections describe the different components that make up the Bendi B40i4 Forklift.

Frame

The frame consists of 3/8" to 1" thick (9.525 mm to 25.4 mm) steel panels welded together to form the backbone of the truck (basic truck shape). A number of thick rectangular steel shapes (counterweights) are welded within the frame to counterbalance the truck against the weight of its load. The rear wall of the truck also includes a thick steel plate to add additional counterbalance.

NOTE

The weight of the engine is also used as counterbalance.

Brake System

The brake system uses two independent methods. The use of the drive pedal to actively control hydraulic pump displacement and the stop pedal to provide a mechanical lock-up at the drive motors.

The hydrostatic drive system will act as a service brake. Braking sensitivity can be controlled by releasing the drive pedal slowly or quickly.



CAUTION

The stop pedal is to be used for emergency stops or as a parking brake ONLY!

This Bendi B40i4 forklift is equipped with a spring applied hydraulic released brake system. The stop pedal does not operate as a gentle service brake, but a firmly acting parking brake. If possible do not operate the stop pedal while the forklift is in motion as this could result in the loss of the load from the forks.

As the stop pedal is depressed, the drive motor shuts down and the direction control electrically resets to NEUTRAL, preventing further movement of the truck.

Parking Brake

A parking brake system is fitted to both drive units. The system is foot pedal actuated, and is electrically interlocked to create a NEUTRAL condition when the brake lever is actuated.

The parking brake system consists of an overcenter latch to hold the top pedal in the down position.

To continue, the operator must first set the direction control lever to NEUTRAL, release the parking brake, then set the control lever to the desired direction of travel.

Electrical System

The electrical system includes a 12V battery, key switch, fuses, gauges, switches, electrical harnesses, and diagnostic ports for J1939.

Traction

Bendi B40i4 Model trucks are dual-drive, four-wheeled trucks, having two steerable, articulating load support wheels in the front and two drive wheels in the rear. The rear drive is operated by a single hydraulic circuit consisting of a variable displacement hydraulic pump and radial piston hydraulic motors. The variable displacement hydraulic pump is controlled by the vehicle master controller (VMC).

LPG Gas Engine

Features

The Bendi B40i4 Model truck is powered by a Liquefied Petroleum Gas (LPG) engine, designed to minimize emissions.

Fuel is supplied from a standard 33 or 43 lb. ICC gas cylinder tank mounted horizontally on the rear deck of the truck. The tank is held in the tank mount plate attached to the truck using a strap and latch. See Figure 3-5.

An ultrasonic fuel level sensor is mounted to the back mount plate. This sensor provides the operator with an accurate quantity of fuel left through the dash display.

The engine muffler is equipped with baffles to block the ejection of sparks or flame, and meets standards required by the Forest Service of the U.S. Department of Agriculture.



Figure 3-5: LPG Tank Mount

Key switch

The Key switch switches electrical power to start and turn off the truck. See Figure 3-12.

Safety Interlock

Both a key lock switch (Keyswitch) and an operator's seat switch must be engaged before the truck can move. The seat switch is activated when the operator is seated in the driver's seat. See "Seat Safety Switch" on page 1-6 for additional information.

Battery

A 12-volt lead acid battery provides electrical power for the engine, lights, and other auxiliary equipment. For maintenance and/or emergencies, turn off the key switch to stop power to the truck.

For maintenance, the driver's seat compartment cover and a hinged side cover, provides easy access to the engine compartment where the battery is located.

Hydraulic System

The hydraulic system consists of two separate circuits driven by a through shaft system originating at the pump drive attached to the flywheel on the engine. The first of these circuits is the hydrostatic drive and the second is the auxiliary pump circuit.

Hydrostatic Drive

The hydrostatic drive is comprised of a variable displacement pump plumbed to a fixed displacement motor for each of the two drive wheels all controlled by the Vehicle Master Controller (VMC). The operator sends a direction and throttle signal to the VMC via the operator's controls. The VMC in-turn sends a throttle signal to the engine control module and a command to the variable displacement pump. This pump then sends oil at pressure to the wheel motors. The wheel motors then rotate the drive tires with speed and torque. Refer to the VMC section of the Service Manual for additional information and calibration instruction and procedures.

Auxiliary Pump Circuit

The auxiliary pump is located on the front of the variable displacement pump. The auxiliary pump provides oil pressure to the Steering, Hydraulic Fan and Mast Valve.

Steering

Steering is controlled by the steering control valve, or orbital, metering oil supplied by the auxiliary pump based on the operator's input to the steering wheel. Pressurized oil from the steering control valve is sent through a motion control valve to the hydraulic steering motor. This motor turns actuator, which rotates the front plate and mast.

Hydraulic Fan

The oil flow to the hydraulic fan is regulated by a proportional valve controlled by the VMC. The fan speed is controlled by varying the oil flow based on engine temperature. As engine temperature rises, the fan speed will increase to match the greater cooling demand. Consequently, the hydraulic fan is shut off when full mast lift is commanded to allow all hydraulic fluid flow to the mast.

Mast Valve

Oil supplied by the auxiliary pump, not used by steering or the hydraulic fan is directed to the 3-spool mast control valve. An inlet relief controls pressure in this branch of the auxiliary pump circuit. The 3-spool valve directs lift circuit pressurized oil to the lift, tilt, and side shift functions based on the operator's shifting of the valve levers. In the event that an attachment or 4th function is added, oil from the side shift spool is split to go either to the side shift cylinders or the 4th function based on the signal from a push-button switch mounted to the spool control lever.

Filtration and Cooling

Return oil from the steering function, hydraulic fan and lift function are combined at the filter manifold and sent through the hydraulic cooler to be cooled. Cooled oil from the hydraulic oil cooler is then sent through the in-tank hydraulic oil filter.

The following sections briefly describe how each of the hydraulic functions operate:

Mast Controls

Mast positioning is achieved by operating the proportional control valve via the mast control lever. Hydraulic pressure is provided by the secondary pump. Mast movements may be operated individually or together, however, when operated together, the speed of operation is somewhat limited.

Mast Lift

The mast lift circuit provides the means for lifting and lowering the mast and fork assembly. The mast lift consists of three hydraulic cylinders - one primary and two secondary, a velocity fuse and a flow regulator.

Mast Tilt

The mast tilt circuit provides the means for tilting the mast and fork assembly forward and back. Tilting movements are accomplished through the use of two hydraulic double-acting cylinders mounted to the top of the front plate.

Mast Side Shift

The side shift circuit provides the means for moving the carriage laterally (left-to-right). Side shift movements are accomplished using a double acting hydraulic cylinder that pushes the carriage side to side, mounted on nylon slides.

Mast Lift Assemblies

Various mast assembly configurations (triplex or quad) can be applied to the B40i4 Model trucks to provide both collapsed and extended heights suitable for all customer requirements. The lifting capacity of the mast also varies depending on the truck and its application. Load capacities are determined at 24" (609.6 mm) centers, centered on the mast and include all attachments on the carriage. The B40i4 specifications list the dimensions of standard masts available for these trucks. See "Technical Specifications" on page 5-9.

Also check the identification plate in the operator's compartment for the maximum lifting capabilities, based on the particular truck and mast combination. See Figure 3-2.

The trucks are counterweighted to compensate for all positions up to the maximum allowed load.

Masts are engineered to distribute thrust loads evenly between the rollers and rails. Masts move as a unit, providing maximum strength and endurance for the rated load and consist of up to four pairs of channels or rails (steel beams) rolling one within the other on steel rollers. The outer rails provide guidance and support for the middle rails, which in turn guide and support the inner rails. The truck forks are mounted on a carriage assembly that runs on rollers within the inner rails. See Figure 3-6.

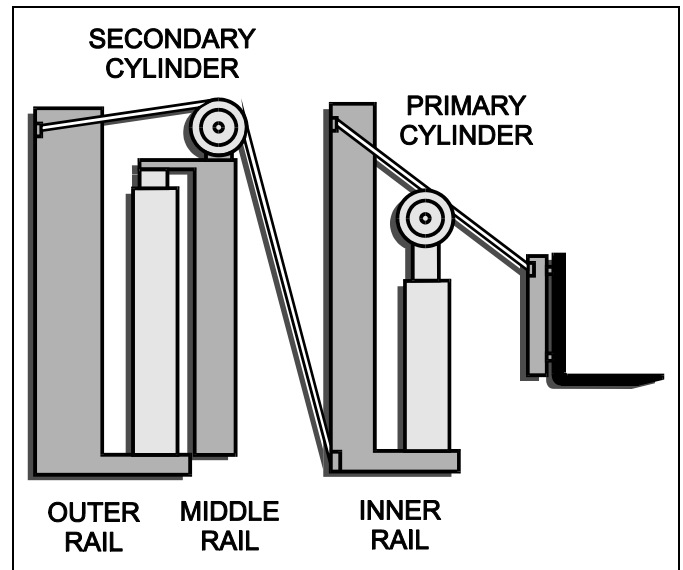

Figure 3-6: Mast in Collapsed Position

On a triplex mast, a primary cylinder is supported by the inner rails and hydraulically controlled. As the primary cylinder rod extends, a sheave and chain assembly lift the fork/carriage upward at twice the distance covered by the cylinder rod. This first stage of carriage lift is called free lift. It is the distance of lift available without increasing the overall height of the mast assembly. See Figure 3-7.

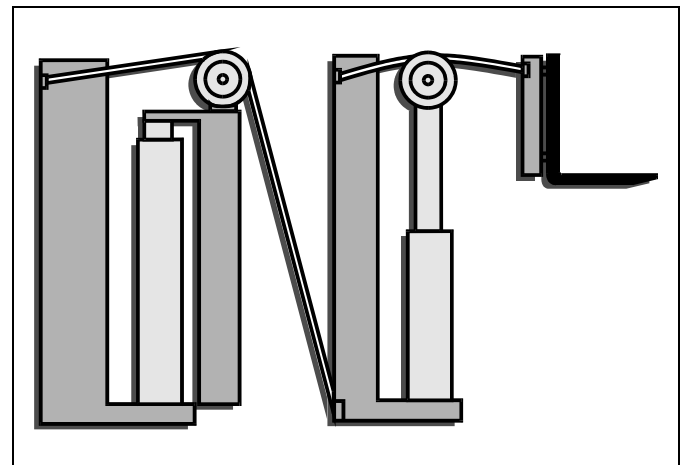

Figure 3-7: Mast in Free Lift Position

A secondary cylinder, attached to the outer rails, lifts the middle and inner rails progressively via chains, rollers and sheaves. The inner rails are raised at twice the rate of extension of the secondary cylinder piston. This upward lift continues until the secondary cylinders are fully extended. See Figure 3-8.

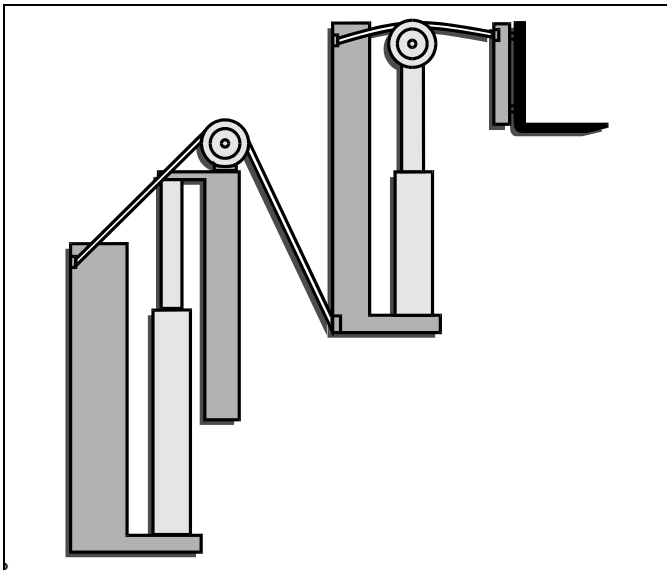

Figure 3-8: Mast Fully Extended

The hydraulic fluid used to lift the primary cylinder is applied sequentially to the secondary cylinder. When the primary cylinder reaches full extension, the secondary cylinder begins to extend. The differences in weights being supported by the cylinders, along with the differences in cylinder diameters, ensure that the primary cylinder will be fully extended before the secondary cylinder can begin to move. Consequently, when the mast is raised, it moves through two phases:

- Free lift, in which only the carriage assembly moves, up to the maximum height allowed by the inner rail. See Figure 3-6.
- Rail extension, in which both the middle and inner rail moves, carrying the carriage upward. See Figure 3-7.

Downward movement of the mast is accomplished by releasing the hydraulic fluid from the cylinders back into the reservoir.

The weight of the rails and carriage(& load) provides enough pressure to force the fluid from the cylinders. When the secondary cylinder piston is fully contracted, the primary cylinder begins to collapse, forcing its fluid back to the reservoir.

The mast is supported by trunnions, which allow it to tilt fore and aft. Two short hydraulic cylinders are mounted between the mast and the pivot arm to control the amount of tilt. A mast indicator gauge (pointer) is located on the both sides of the mast to indicate when the carriage and forks are perfectly level with the floor.

As an option, trucks may be equipped with quad masts which utilize four sets of rails, referred to as Outer, Outer Intermediate, Middle, and Inner rails, respectively. See Figure 3-9.

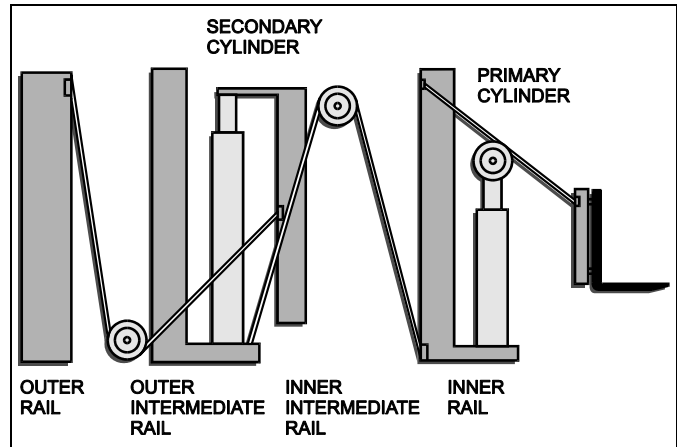

Figure 3-9: Quadplex Mast in Collapsed Position

The primary cylinder and carriage operate the same as a triplex (three-rail) mast. When the secondary cylinders extend, they lift the middle rails. Through an intricate system of chains and sheaves, the rising middle rails pull up the outer intermediate rails at half the middle rail speed, and push up the inner rails at twice the middle rail speed.

Driver Controls

Driving controls for the Bendi B40i4 truck include a stop pedal and a drive foot pedal for speed control, tilting/telescoping steering wheel, Keyswitch, dash display, forward and reverse direction control lever, tilt/lift and side shift controls, horn button, rear view mirror and drivers seat adjustments.



WARNING

- **Driving speed of the truck must be governed by your work environment, such as, slippery floors, cross aisles, slanted driving surfaces, load size, visibility or other people working in the area.**
- **Never travel at speeds with or without a load that could be dangerous to yourself or others. Also see the Safety section in the beginning of this manual, Chapter 1, HEAD AND PAGE.**

Foot Control Pedals

The foot pedals consists of a drive pedal and a stop pedal. The drive pedal is pressed by the driver's right foot to control the speed of the truck.

The drive pedal is the pedal on the right, and the stop brake is the pedal on the left. See Figure 3-10.

Pressing the pedal down starts the truck moving, dependent upon the direction you have selected. The closer you press the drive pedal to the floor, the faster the forklift moves. Releasing the pedal brings the vehicle to a smooth stop.

The drive pedal only controls engine RPM when a direction is selected with the direction lever. Depressing the drive pedal while in NEUTRAL will not increase engine RPM.



Figure 3-10: Foot Pedals

The Bendi B40i4 forklift is equipped with a spring applied hydraulic released brake system. The stop pedal does not operate as a gentle service brake, but a firmly acting parking brake. It is to be used for emergency stops or as a parking brake ONLY. If possible, do not operate the stop pedal while the forklift is in motion as this could result in the loss of the load from the forks.

As the stop pedal is depressed, the drive motor shuts down and the directional control electrically resets to NEUTRAL, preventing further movement of the truck.

Hand Operation Controls

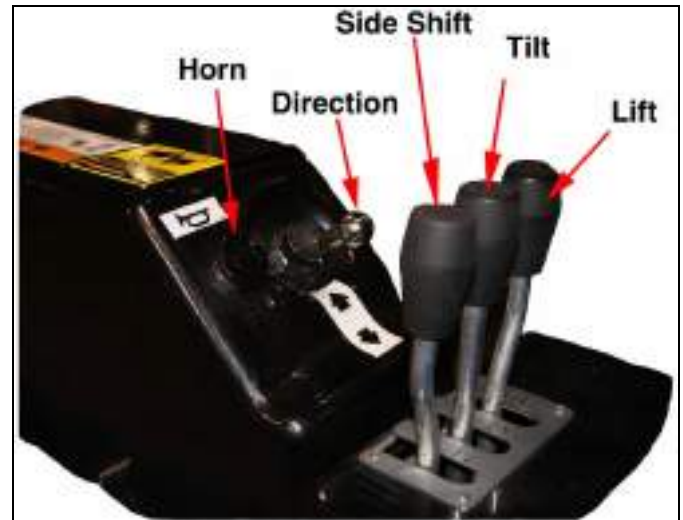

Figure 3-11: Control Levers

Direction Lever

The forklift direction control lever is located on the operators control pod and selects the direction of travel of the truck (forward or reverse). See Figure 3-11.

Lift Lever

The forklift mast lift control lever is located on the front control pod. See Figure 3-11. The lift lever not only controls the lift spool of the hydraulic valve but also provides feedback to the vehicle Master Controller to increase engine RPM while full lift is being selected. This seamless integration allows maximum lift speed without the need to rev the engine manually.

Tilt Lever

The forklift mast tilt control lever is located on the front control pod. See Figure 3-11. A visual indicator is provided on the mast tilt cylinder, located on both sides of the mast, so you can easily determine the number of degrees the mast is tilted.

Side Shift Lever

The forklift mast side shift control lever is located on the front control pod. See Figure 3-11. Side shift is a standard function on Bendi B40i4 forklifts.

Attachment Lever(s) - Option

A fourth optional function can be fitted via a push button controlled solenoid. The push button is mounted on the side shift lever. Powered attachments are optional functions on Bendi B40i4 forklifts.

Horn

The horn control button is located on the control pod, just to the left of the direction control lever. See Figure 3-11.

Rear View Mirror

The rear view mirror is attached to the front top of the overhead guard. The mirror is adjustable up and down, and side to side.

Driver's Seat

The driver's seat is adjustable to accommodate the driver's weight (seat cushion spring tension), backrest tilt and distance from the pedals.

The seat also includes a circuit interrupt safety switch, reference "Seat Safety Switch" on page 1-6.

Seat Belt

The driver's seat belt must always be worn correctly, low and flat across your lap, when driving this truck.



WARNING

A twisted belt can seriously injure you. In a crash or a tip-over, the full width of the belt is required to absorb the impact forces.

Steering Wheel

The steering wheel, is equipped with a steering knob, which should be held firmly with your left hand at all times. The steering column tilt and height are both adjustable using the tilt clamp. See Figure 3-12.



Figure 3-12: Steering Wheel and Knob

Switch Panel

The operator switch panel includes three on/off rocker switches to activate optional packages installed on your truck. The left is for headlights, the middle is saved for future use and the right is for 12V accessories or additional options.

Dash Display

The Dash Display is located in the center of the console, in front of the steering wheel. See Figures 3-1 and 3-13.

The Dash Display shows engine coolant temperature gauge, fuel gauge, hour meter, clock, warning icons and display function buttons.



Figure 3-13: Dash Display

Understanding Stability



DANGER

- Never load a lift truck beyond its rated capacity. Loading beyond rated capacity can cause axles to break, trucks to tip over, loads to fall, causing serious injury or death. See identification plate for rated capacity and load center information.
- Never allow anyone to stand beneath or pass under the lifting mechanism.
- Make sure that the load is centered and the forks are fully engaged.
- Failure to do so can cause the load to fall, or the truck to tip over, resulting in serious injury or death

The leading causes of accidents involving forklift trucks are due to the lack of understanding how forklift trucks operate, especially when it comes to stability.



DANGER

If you don't understand the concepts of stability, you run the risk of tipping over the Bendi B40i4 forklift truck, which can cause serious injury or death.

Basic Principles

The concepts concerning stability are relatively easy to understand. As the angle between the forks and the body of the truck approaches 90° to the right (See Figure 3-14) or left (See Figure 3-15), the truck is in its least stable position. Unlike an automobile which has four points of suspension, the Bendi B40i4 forklift truck operates on a three-point suspension. When the forks are turned nearly 90° to the right, two of the suspension points are on the rear axle (item 1) and (item 2). The third suspension point is the center point of the front wheel (item 3). The center of gravity, an imaginary point at which all of the truck's weight is concentrated, is located as shown (item 4) when:

- The forks are turned nearly 90° to the right.
- No load is placed on the forks.
- The truck is at rest.

In this position, the fulcrum, or axis around which the truck will tip, is between suspension point (item 2) and (item 3).

- If you try to pick up a load that is too heavy, the truck will tip around the fulcrum. Imagine a triangle (item 5), drawn between the three suspension points.

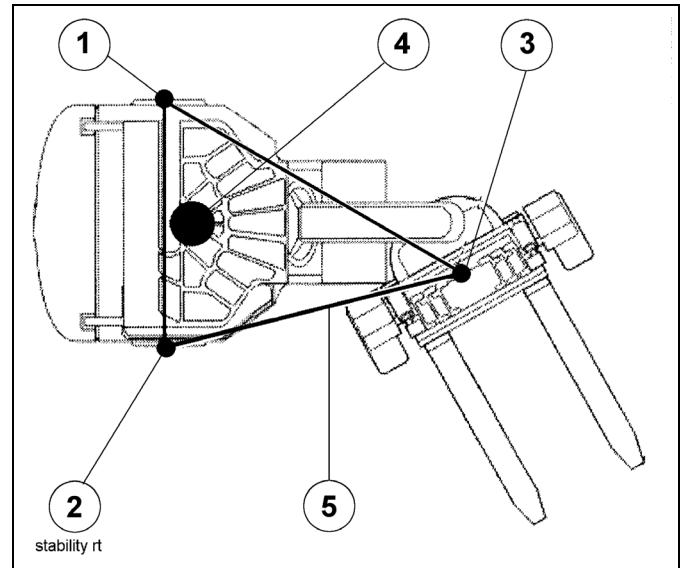

Figure 3-14: Right View 90° Stability

This triangle is commonly called the stability triangle. Since the center of gravity is an imaginary point, it will shift for various reasons. The crucial thing to remember is, as long as the center of gravity of the truck remains within the border of the stability triangle, the truck will not tip. If the center of gravity shifts so it falls outside of the border of the stability triangle, the truck will tip around the fulcrum.

Again, imagine a triangle, drawn between the three suspension points. The forklift is most vulnerable in three conditions: See Figure 3-15.

1. When the forks are loaded, the load is shifted to the left, and the forks are straight ahead, the center of gravity moves to a point along the axis between points (1) and (3).
2. When the forks are loaded, the load is shifted to the right, and the forks are pivoted 90° to the right, the center of gravity moves to a point along the axis between points (2) and (3).
3. When the forks are loaded and the load is too heavy or not properly distributed, the center of gravity moves to a point along the axis between points (1) and (2).

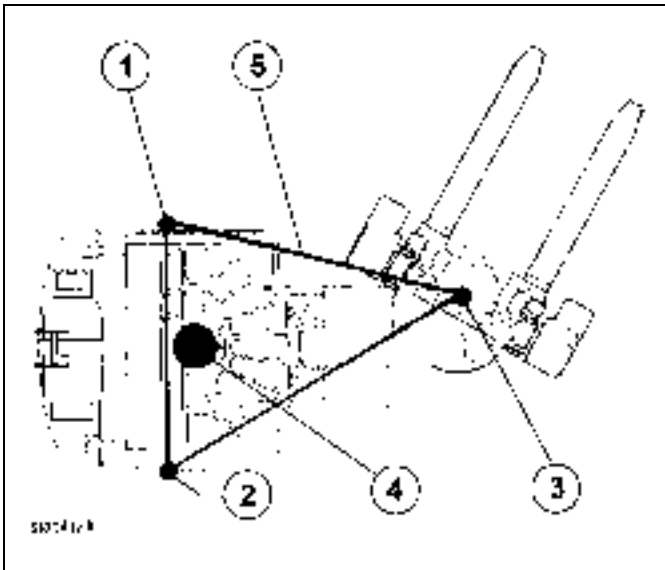

Figure 3-15: Left View 90° Stability

The center of gravity will also shift if:

- The load exceeds the rated capacity listed on the identification plate.
- The load exceeds the load center dimensions listed on the capacity plate.
- You do not seat the forks fully into the pallet, called “tip loading”.
- You take a corner too fast (with the truck unloaded or loaded).
- You drive with the load raised.
- The load is not distributed properly (always keep the heavier items near the load backrest).
- You drive across a slope.
- You drive on a slope with the load facing downhill.

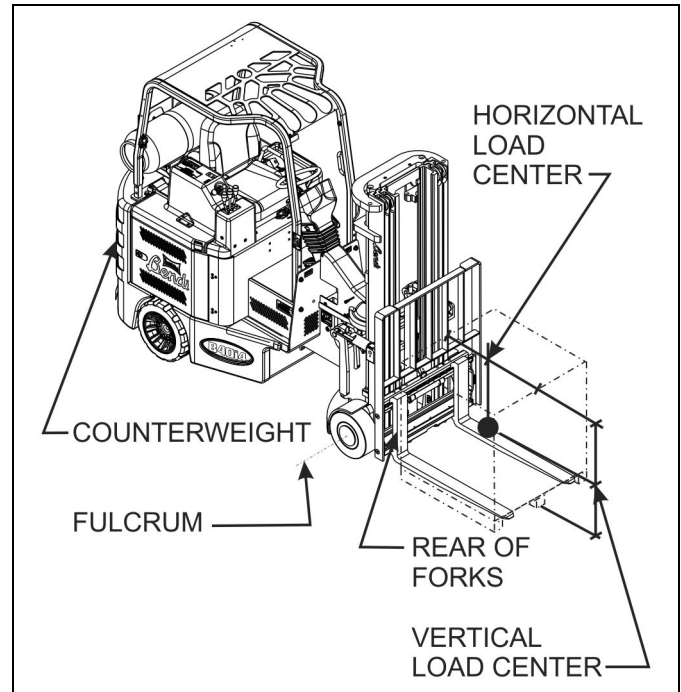

Figure 3-16: Load Center Rating

Load Center



DANGER

Make sure the actual horizontal and vertical load centers do not exceed the maximum load centers stated on the identification plate.

Failure to do so can cause the forklift to tip over causing serious injury or death.

You need to consider *two types* of load centers. The *horizontal* load center is equal to one-half the *length* of the load when the weight is evenly distributed. For example, a load that is 48 in. long has a horizontal load center of 24 in. The further the load center is from the fulcrum, the less stable the forklift. Always make sure your load is flush against the rear of the forks, and that unevenly distributed loads are loaded with the heaviest end of the load closest to the front wheels. See Figure 3-16.

The *vertical* load center is equal to one-half the *height* of the load when the weight is evenly distributed. For example, a load that is 48 in. high has a vertical load center of 24 in. Make sure that you **do not** pick up a load that is higher than twice the *vertical* load center.

The maximum *horizontal and vertical* load centers your Bendi B40i4 forklift can handle is listed on the identification plate.

Counterweight



DANGER

Never let anyone stand on the back of the forklift to add counterweight. They can fall off the forklift, or the truck can tip backwards, causing serious injury or death.

The engine, left frame plates and bottom plate serve as counterweights and allow the Bendi B40i4 forklift to travel with heavy loads. When the forklift lifts a heavy load, the counterweights keep the center of gravity inside the stability triangle and prevent it from tipping over. See Figure 3-16.

Maximum Fork Lift Height



DANGER

The load capacity of your forklift decreases the higher you raise the forks. Refer to the rated capacity at the heights listed on the identification plate. Failure to observe these guidelines can cause your forklift to tip over, causing serious injury or death.

The maximum fork height is the highest position the Bendi B40i4 forklift can lift a load. See Figure 3-17. This is measured from the floor to the forks when they are raised in their highest position. The higher the forks are raised, the less stable the forklift becomes.



Figure 3-17: Maximum Lift Height B40i4

Tilting Considerations

The amount of forward and rearward tilt you should use is governed by the application. When you travel with the truck loaded, you should tilt the mast rearward as well as keep the load low. This will help stabilize loads with an uneven weight distribution. When you load at high heights, tilt the load back far enough to seat it against the load backrest or forks. When you unload at high heights, make sure you only use enough tilt to place the load onto the rack or stack.

Attachments



DANGER

Never modify the Bendi B40i4 forklift in any manner. Only options and attachments approved by Landoll may be installed on the truck. Other modifications will void the warranty and can cause serious injury or death.

Attachments to the forks may affect the load center. When the factory, dealer, or distributor installs attachments approved by Landoll, a modified identification plate is attached to the truck. The new plate identifies the type of attachment, the changes in the load centers, and the rated capacity. It is illegal to use attachments for which revised capacities are not available.

Determining the Weight of the Load

In addition to the rated capacity you must determine the weight of the load **before** you attempt to lift it with the Bendi B40i4 forklift:

- Weight is listed on pallet wrapper.
- Weight is listed on Bill of Lading.
- Weight is determined by multiplying the weight of each small container by the number of small containers on a pallet. Each small container should be marked with its weight.
- When in doubt ... Ask your supervisor.

Understanding Workplace Conditions



DANGER

Workplace situations are constantly changing. Check your area before beginning work for the day. If in doubt, check with your supervisor. Failure to observe new workplace conditions may lead to serious injury or death.

In addition to stability, you need to be aware of special situations in your workplace to avoid forklift accidents. Even if you work in the same area each day, there could be changes that would affect your safety, such as:

- Contractors doing maintenance.
- Wet areas.
- Overhead repair work.

Be on the defensive for anything that might present a hazard. Other situations that could present special operating conditions include:

- Potholes.
- Pedestrian traffic.
- Very narrow aisle ways.
- Overhead obstructions.
- Poor lighting making it hard to see hazards.
- Wet, oily, or uneven terrain.
- Other equipment or vehicles operated in the area.

IMPORTANT

Do not block the following items with the Bendi B40i4 AC forklift, or materials you are moving:

- Electrical panels.
- Fire exits.
- Emergency stop buttons.
- Aisle ways.

Working in Hazardous Environments



DANGER

Some atmospheric conditions encountered in the workplace are extremely explosive and/or flammable. Make sure the Bendi B40i4 forklift is designated with the type appropriate for your workplace. If you are unsure about the forklift, check with your supervisor. Using the wrong type designation can cause an explosion or fire resulting in a serious injury or death.

Chemical Hazards

You should know the chemical characteristics of the substances you are moving. In case of an accident you would handle stable, reactive, or flammable substances differently. For example, if you puncture a drum that contains flammable material, you need to turn off all sources of ignition and contact the proper authorities.

Operating the B40i4 Forklift

This chapter of your Bendi B40i4 Forklift Operator's Manual explains the concepts that must be thoroughly understood to operate a Bendi B40i4 forklift.



DANGER

Read the “Before You Begin (Please Read)” on page 1-1, Chapter 1, in this manual. It contains valuable information, such as stability and rated capacity information you need to know before you operate your Landoll forklift.

Your employer is to make training available, to ensure that you are competent to safely operate the type of forklift that you will be using in the workplace. More information on operator training requirements is included in, Chapter 1, “Operator Safety Training” on page 1-6. Failure to follow the information provided in the “Before You Begin” section or failure to receive proper operator training can cause serious injury or death.

Operator’s Daily Inspection

NOTE

Daily inspection is a necessary requirement.

Report any defect immediately to your supervisor.

You are responsible for the daily inspection of your Bendi B40i4 forklift: See “Daily Checklist” on page 5-1.

- Photocopy the Operator’s Daily Checklist in this Bendi B40i4 Operators Manual, shown in Chapter 5, page 5-1, or use the form supplied by your supervisor.
- Inspect the truck and fill out the form.
- Report defects and return the form to your supervisor.

Basic Operating Instructions



DANGER

Check all systems before operating this vehicle. Report unsafe conditions and correct them before operating vehicle.

Do not operate vehicle unless trained and authorized to do so.

Every forklift operator is to be trained in accordance with rules provided by OSHA, relating to Forklift Trucks.

Operating a powered industrial truck without the proper training can cause serious injury or death.

IMPORTANT

The guidelines here are to give additional information related to this specific forklift truck. This information should never be used in lieu of driver training.



WARNING

To avoid personal injury when operating the truck, be extremely careful that NO part of your body (head, feet, arms, legs) is outside the operator’s compartment where it could be subject to injury by aisle supports, other trucks, the mast raising or lowering, or any obstacle in the area.



DANGER

Look in the direction you will travel before you begin to drive the forklift.

Failure to look in the direction you are traveling can cause serious injury or death.

Before you operate your Bendi B40i4 forklift, familiarize yourself with the controls and indicators. Practice going forward, backward, turning, stopping and parking without a load on the truck. After you become familiar with the truck's operation, learn how to load and unload the forklift.

As the truck operator, you are responsible for observing all speed restrictions and traveling in accordance with aisle and work area conditions.

You are responsible for observing all instructions and safety regulations during your daily work routine related to the use of this truck.

It is your responsibility to thoroughly read the Operator's Manual, paying particular attention to Chapter 1, primarily devoted to Safety, before attempting to operate this truck.

Under normal driving conditions, speed must be chosen according to the situation, such as surface conditions, visibility, people working in the area, moving and fixed objects in the area, cross aisles, etc.

Where visibility is restricted, always travel at very slow speed and ask for a helper ("Banksman") to guide you through the area.

Getting On and Off the Forklift

Always maintain a three-point contact when you get on and off the forklift. Use the steps and hand grips provided for this purpose.

Driving Position



DANGER

- **Only operate the vehicle from the operator's seat with the seat belt fastened.**
- **Do not place any part of your body outside the vehicle.**
- **Do not carry passengers.**
- **Failure to follow these guidelines can result in serious injury or death.**

For proper seating position:

1. Adjust the driving seat for comfortable operation of the forklift controls. See Figure 4-6. You must be correctly seated with all body parts inside the cab.
2. Fasten your seat belt. See Figure 4-5.



DANGER

Remain in your seat with the seatbelt fastened while the truck is moving. Your seatbelt will help you remain inside of the truck should it tip over. Never jump from the truck if it begins to tip. The truck may land on you causing serious injury or death.

Starting and Traveling

Failure to follow this procedure will result in traction not being enabled.

1. Make sure the LPG tank is properly mounted and connected. Open tank valve slightly until pressure equalizes. Then open the valve the rest of the way.
2. Sit in the seat and face forward. Be sure the parking brake is applied.
3. Set the direction lever to neutral. See Figure 4-4.
4. Turn the Keyswitch to the Start position, when engine has started, release and allow Keyswitch to return to on, run position.
5. Use the operator controls to raise the forks from the ground and tilt the mast back. According to ANSI B56.1, travel with the forks as low to the ground as possible. This is the recommended traveling position.



WARNING

Driving with the mast in the traveling position improves driver visibility and improves the stability of the truck by reducing the possibility of personal injury or damage to the load.

6. Hold the steering knob firmly with your left hand.
7. Release the parking brake.
8. Set the direction of travel.
9. Gently depress the drive pedal as required to achieve a safe operating speed.

Turning



DANGER

A lateral tip-over can occur if your truck is improperly operated.

Slow down before turning!

Failure to slow down can cause serious injury or death.

When you reach an intersection:

- Slow down. Even if the forklift is not carrying a load it can tip-over if you turn at a high rate of speed.
- Sound the horn as you reach the intersection to warn pedestrians and other equipment operators you are approaching the intersection.
- Always follow the rules of the road and yield to other equipment operators and pedestrians as required.

Stopping



DANGER

When you stop, stay inside the cab until the truck comes to a complete stop.

Failure to stay inside the cab can cause serious injury or death.

Do not stop abruptly with the load raised or tilted forward. If you stop abruptly the load may dislodge from the forks causing serious injury or death.

To slow down, release the drive pedal, and the truck will automatically slow down and stop.

For an emergency stop, release the drive pedal and press hard on the foot Stop pedal with your right foot.

Stopping Distance

Stopping distance changes with the incline and quality of the road surface.

To make sure you come to a safe stop:

- Reduce speed.
- Allow adequate distance between the truck and any other vehicle, object or person.

Parking



DANGER

When you exit the vehicle, place controls in neutral and set the foot brake. If you leave the truck unattended, fully lower the mast, turn the truck Off and remove the key.

Failure to properly exit and park your forklift can cause serious injury or death.

Before you park the vehicle make sure:

- The parked truck will not cause an obstruction or safety hazard.
- The forklift is clear of fire exits, fire equipment and stairways.
- The truck is not to be left unattended on an incline. If the truck is inoperative and you must leave it parked on an incline, securely block the wheels and remove the key.

When you park your forklift always:

1. Apply the foot park brake.
2. Tilt the mast forward.
3. Lower the forks to the ground.
4. Place in neutral, turn the Keyswitch to the OFF position and remove the key.

NOTE

Make sure all accessories are off (lights, etc.) before you turn the Keyswitch to the Off position.

Setting the Forks



WARNING

Make certain the truck Keyswitch is in the OFF position.

The forks must be set equal distance from the center of the fork carriage.

Setting them too far to the left or right could cause a load to unbalance and tip the truck.

Before you get on the forklift make sure the spacing between the forks is properly set. See Figure 4-1.

1. Measure the center to center between the fork openings on the pallet.
2. Lift the fork locks up. See Figure 4-2.
3. Move the forks until the center to center spacing is equal to the center to center distance. Make sure the forks are seated in a carriage notch and equidistant from the ends of the carriage.



WARNING

Never pull a fork toward you as this places your hands in a possible pinch position, which could cause serious injury. Always push the fork away from your body.

4. Press the fork locks down to ensure locking.

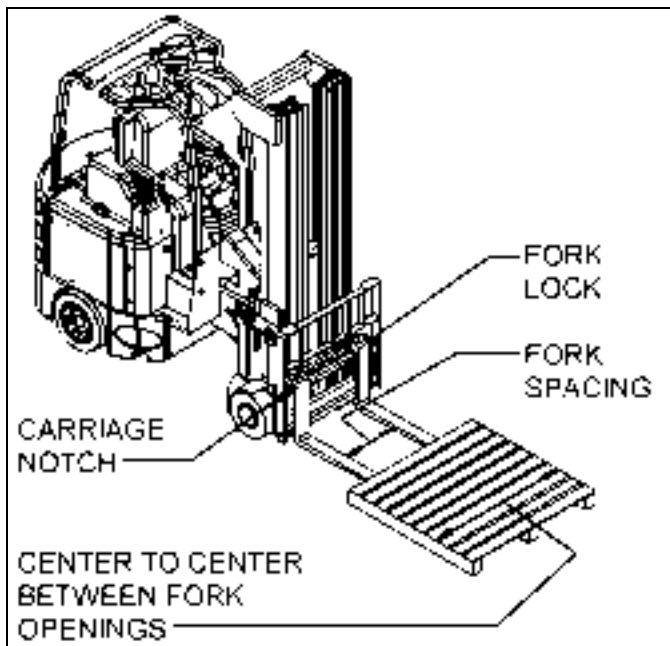

Figure 4-1: Setting the Fork Spacing

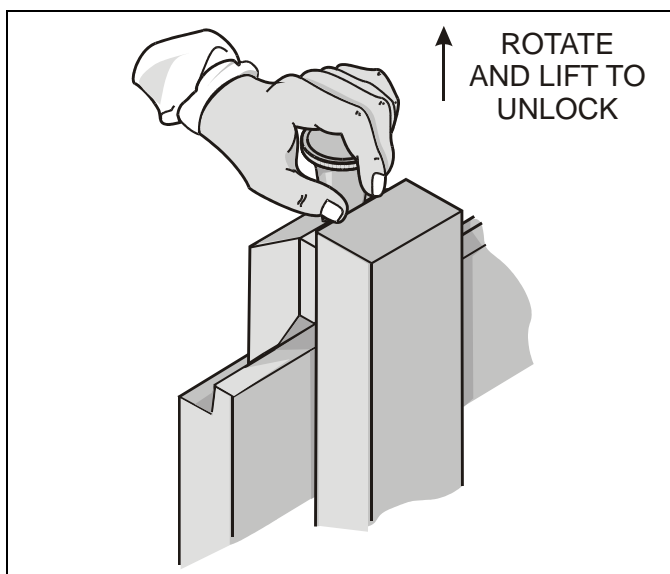

Figure 4-2: Setting the Forks

Operator Controls and Indicators

This section explains how each control and indicator on the Bendi B40i4 forklift operate and identifies their location with an illustration.

NOTE

The operation of each control is established by the American Society of Mechanical Engineers (ASME) or Industrial Truck Association (ITA). If you notice that the control operation deviates from the way it is described in this manual, report the operation to your supervisor.

Key switch

Switches electrical power to the truck ON and OFF and starts the engine. Starter lockout prevents restart of running engine (See “Lock Out/Tag Out” on page 1-6).

Drive Pedal

The drive pedal is located on the floor to the right of the Stop pedal. See Figure 4-3.

Pressing the pedal down starts the truck moving, dependent upon the direction you have selected. The closer you press the drive pedal to the floor, the faster the forklift moves. Releasing the pedal brings the vehicle to a smooth stop.



Figure 4-3: Drive and Stop Pedals

Stop Pedal

The stop pedal is located on the floor to the left of the drive pedal. See Figure 4-3.

Pressing the pedal down stops the truck movement in case of emergencies.

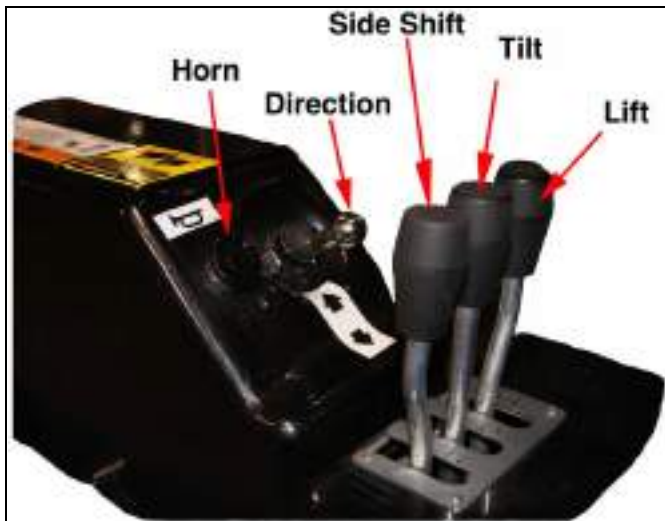

Figure 4-4: Operator Controls

Direction Control Lever

The direction lever is located near the front of the armrest. See Figure 4-4.

Push the lever away from you for forward travel and pull it toward you for rearward travel. The lever may be moved while the truck is in motion “known as “brake by plugging”. The motor will automatically come to a smooth stop and then reverse direction.

Placing the lever in neutral while traveling will bring the vehicle to a quick stop. While in neutral you may notice possible slight movement to the left and right. This does not effect the performance of the lift in any way.

Lift Lever

The first lever (closest to the operator) near the front of the armrest is the lift lever. See Figure 4-4.

Pull it back to lift the forks and push it forward to lower the forks.

Tilt Lever

The second lever on the front of the armrest is the tilt lever. See Figure 4-4. Visual indicators on both sides of the mast are provided so you can easily determine the number of degrees the mast is tilted.

Pull it back for backward tilt and push it forward for forward tilt.

Side Shift Lever

The third lever, away from the operator, near the front of the armrest, is the side shift lever. See Figure 4-4.

Side shift is a standard function on Bendi B40i4 forklifts. Pull it back to shift to the right; push it forward to shift to the left.

Horn

The horn is located on the armrest. See Figure 4-4. Depress the button to sound the horn.

Seat Switch

A seat switch, built into the seat, tells the vehicle master controller when you are in the operator’s seat. Traction operations will shut down after a small delay if the seat switch opens, signaling that you are not in the operator’s seat.

Seat Belt

The driver’s seat belt must always be worn while driving a forklift truck.

1. Sit up straight in the driver’s seat.
2. Pull the belt across you. Do not let the belt twist. The belt may lock if you pull it across too quickly or stop too soon. If this happens, let the belt go back slightly to unlock it, then pull the belt across slowly.



WARNING

A twisted belt can seriously injure you. In a crash or a tip-over, the full width of the belt is required to absorb the impact forces.

3. Push the latch plate into the buckle until it clicks. Pull up on the latch plate to make sure it is secure. If the belt stops before reaching the buckle, let it go back all the way, then start again.
4. The lap part of the belt must be worn low and snug on the hips, just touching the thighs.

IMPORTANT

Make sure the release button on the buckle is set so you can unbuckle the seat belt quickly in an emergency.



Figure 4-5: Seat Belt Latch

Seat Adjustments

A lever under the front of the seat releases the catch for forward or backward seat adjustment. See Figure 4-6. Weight or suspension adjustment is controlled by a seat adjustment. A gauge showing the adjusted level is located to the right of the adjustment handwheel.



Figure 4-6: Seat Adjustments

Steering Wheel

The steering wheel is equipped with a steering knob, which should be held firmly with your left hand at all times. See Figure 4-7.

Steering Column



Adjusting the steering column while driving the truck is dangerous. Adjustment of the column while driving will cause you to lose control of the truck. Adjust the steering column only when the truck is not being driven.

The steering column is adjustable.

Release the tilt steering adjust clamp on the left side of the column and adjust the angle of the steering column. If loosened more you can also adjust the height of the steering column.

Tighten the clamp before driving the forklift.



Figure 4-7: Steering Console Components

Dash Display

The Dash Display is centered in front of the steering wheel. See Figure 4-8. It displays Engine Coolant Temperature, Fuel, Hour Meter (accurately displaying active operating hours), Clock, Warning Icons and overall truck operational mode and status.



Figure 4-8: Dash Panel Display

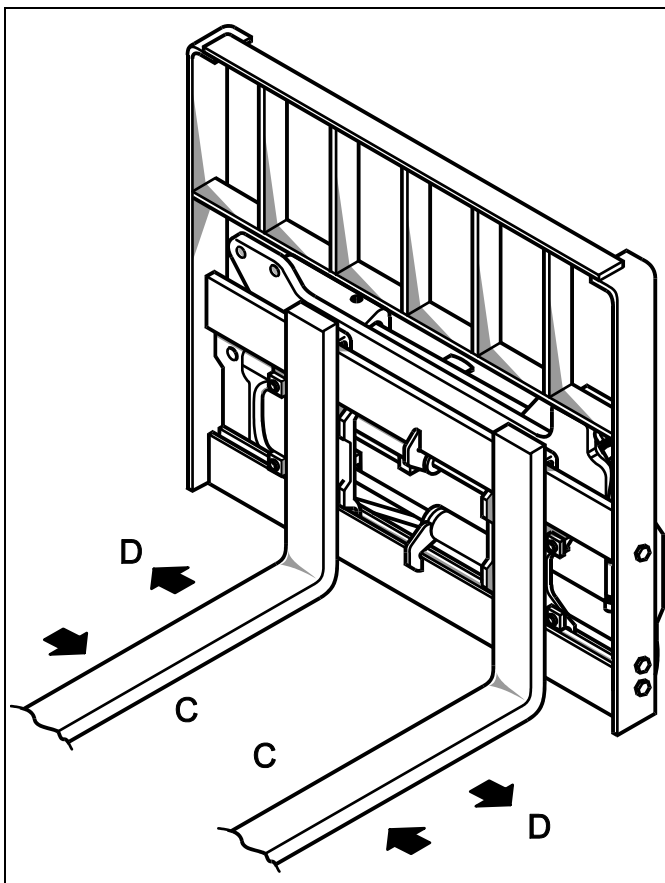

Figure 4-9: Fork Positioner

Fork Positioner, Non-Side Shifting

Fork positioner options are hydraulically driven units that allow the forks to move equal distance from each other to accommodate the size of the load being moved (See Figure 4-9).

The forks start at the center of the carriage and move equal distance to the outside and back again as indicated by letters C and D (See Figure 4-9). A push button is added to the side shift control lever.

Precautions for LP Gas Engines

CAUTION

- Do not run at low idle for prolonged periods.
- Never operate engine faster than governed speed. Excessive speeds are harmful. The governor is set at the factory and needs no adjustment.
- Immediately after the engine starts, ensure the low oil pressure icon has gone out. If it is not, stop the engine and inspect the oil system to find the cause of failure. If you are unable to find the cause, be sure to consult your service personnel before operating the engine. Under no circumstances attempt operation without oil pressure.
- Make sure all gauges are in the normal operating zone before operating the truck.
- Frequently read the dash display indicators.

Liquefied Petroleum Gas (LPG)

A fuel gauge is embedded, as an icon, in the LCD dash display. The gauge indicates the amount of fuel in the tank. The fuel icon flashes when there is less than 10% remaining in the tank.

LPG Tank Removal

Use the following procedure to remove the LPG tank:

1. Removable LPG tanks can be replaced indoors only if the lift truck is a minimum of 25 feet (8 meters) from any open flame or ignition source.
2. Move the lift truck to the area where LPG tanks are changed.
3. Turn the tank shut-off valve clockwise until the fuel valve is completely closed.
4. Run the engine until it stops, then turn the Keyswitch to the OFF position.
5. Disconnect the quick disconnect fitting.
6. Release the tank latch & remove from the bracket.



WARNING

Use only an approved LPG tank. Do not use an LPG tank that is damaged. A damaged LPG tank must be removed from service.



WARNING

- Close the shut-off valve on the tank when parking the lift truck more than momentarily.
- Do not park the lift truck near heat or ignition sources.
- Do not store LPG tanks near heat or an open flame. For complete instructions on the storage of LPG fuels, refer to ANSI/NFPA 58 and 505.
- LPG is extremely flammable. When checking or filling an LPG tank stop the engine and stop smoking.
- Frost on the surface of the tank or at the valves/fittings and/or the odor of LPG fuel indicates a leak. Inspect the LPG system and repair a leak immediately. An LPG fuel leak can create an explosion and fire hazard. Do not attempt to start the engine if there is a leak in the LPG fuel system.
- Only trained and authorized personnel are permitted to operate refueling equipment.
- LPG tanks are heavy. The weight of an LPG tank can exceed the maximum recommended weight for safe lifting by an individual. Get assistance when lifting or lowering an LPG tank. Use correct lifting procedures.
- Fill the LPG tanks outdoors. Stay at least 50 feet (15 meters) from buildings, motor vehicles, electrical equipment, or other ignition sources. Stay at least 15 feet (5 meters) from LPG storage tanks.

2. During the fill operation, the LPG tank must be in a position so that the liquid level indicator will always be in the vapor space above the liquid level.
3. Open the liquid outlet valve and by-pass return valve on the storage tank.
4. Start the pump.
5. Connect the supply hose to the quick disconnect fitting on the LPG tank. If the LPG tank has an auxiliary fill fitting, connect the supply hose to this fitting. Make sure the correct adapter is used to connect the supply hose to the auxiliary fill fitting.
6. Open the vent valve on the liquid level indicator.
7. Open the shut-off valve on the LPG tank.
8. Open the valve on the end of the supply hose.
9. Watch for a discharge from the vent valve on the liquid level indicator. When a cloud of visible vapor appears, the LPG tank is full.
10. Do not fill the LPG tank more than the maximum level indicated by the liquid level indicator.
11. Immediately close the valve at the end of the supply hose.
12. Close the vent valve on the LPG tank.
13. Close the shut-off valve on the LPG tank.
14. Disconnect the supply hose.
15. Stop the pump.
16. Close the liquid outlet valve and the by-pass return valve on the storage tank.

Installing an LPG Tank

Use the following procedure to install the LPG tank:

1. Before the LPG tank is installed on the lift truck, check the operation of the fuel gauge. Look at the fluid gauge and move the tank. If the gauge needle does not move, a new tank must be installed.



WARNING

Make sure the alignment pin extends through the correct hole in the rim of the LPG tank. The hose or the fittings can be damaged if the LPG tank is not installed in the correct position. A damaged hose or fitting can release LPG fuel and cause a fire hazard and/or explosion.

2. Install the LPG tank in its bracket so that the alignment pin is in the correct hole.
3. Close the latch on the tank bracket.
4. Connect the quick disconnect fitting to the shut-off valve on the LPG tank.
5. Use your hand to tighten the fitting. Wrenches are not required on an operational fitting.

Refilling an LPG Tank

NOTE

The following instructions are general procedures. There are variations in equipment for filling LPG tanks. The local authorities that have jurisdiction have specific rules and regulations for filling LPG tanks. Make sure these rules and regulations are available and understood.

Use the following procedure to fill the LPG tank:

1. Check the LPG tank to make sure it needs filling.

6. Turn the shut-off valve counterclockwise to open the valve.
7. Inspect the fuel system for leaks when the fuel valve is open. Frost on the surface of the tank, valves or fittings, or a strong odor of LPG fuel indicates a leak.

Engine Coolant

The coolant level is checked by checking the level in the plastic reserve tank - **not by removing the radiator cap.**

When required, add coolant to the system only at the reserve tank - **not by removing the radiator cap.**

When adding coolant, use the proper anti-freeze solution. Anti-freeze protection must be provided for and checked in both the radiator and reserve tank.

NOTE

The cooling system is filled with an Dexcool Anti-Freeze solution for protection to -10°F(-2°C). Always fill or replace with the same mixture or with a solution of higher concentration for operating in temperatures below -10°F(-2°C).



CAUTION

Never operate the engine without a thermostat as severe engine damage can result through incorrect cooling.

Handling a Load

Narrow-aisles, plus the size of the truck can prevent a load from being pulled straight out of the rack. You must rotate the mast and shift (or inch) the load in or out of the rack. A combination of movements, where rotation or shift actions occur with forward or backward movements of the truck, are needed to inch the load in and out of position. This will require some practice by the operator to be performed smoothly and effectively.

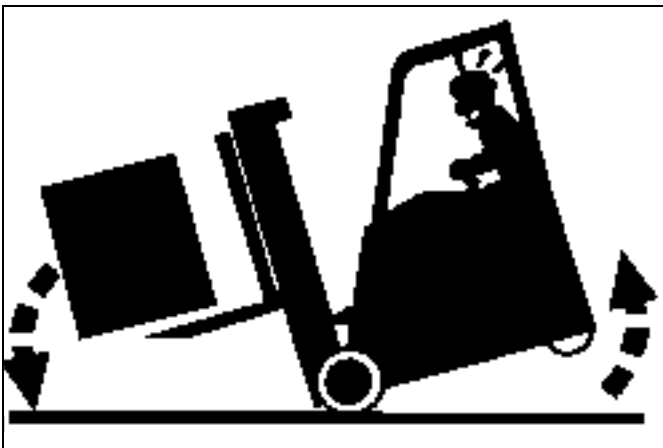

Figure 4-10: Tipping a Load



DANGER

- **Look in the direction you will travel before you begin to drive the forklift.**
- **Make sure forks are set so the spacing between them is equal to one-half the opening between the end stringers on the pallet.**
- **Make sure you insert forks fully into the pallet. Do not “tip load.” See Figure 4-10**
- **Read and understand the information in the “Before You Begin (Please Read)” on page 1-1, section before you operate a Bendi B40i4 forklift.**
- **Do not handle unstable or loosely stacked loads.**
- **Use caution when you handle long, high or wide loads.**
- **Do not allow anyone to stand beneath or pass under the mast.**
- **Never use the forklift to elevate anyone without the use of an approved attachment.**
- **Never carry passengers on the truck.**
- **Never load the Bendi forklift beyond its rated capacity. Rated capacity is stated on the truck’s identification (capacity) plate.**
- **Loading the truck beyond its rated capacity can cause axle(s) to break, the truck to tip over and/or the load to fall.**
- **Make sure the load center of the load does not exceed the load center rating stated on the truck’s identification (capacity) plate.**
- **If the mast continues to raise after the control lever is released, turn off the Keyswitch.**
- **Failure to follow these guidelines can cause serious injury or death.**

Retrieving a Load

NOTES

Actual minimum aisle width will vary based upon application. See Figure 4-11, item 5.

The following illustrations show standard 40 in. x 48 in. (W x L) pallets loaded on a rack with 96 in. beams.

The arrow labeled with an ‘S’ shows the direction you must turn the steering wheel.

Follow these steps to retrieve a load:

1. Approach the side of the aisle that is opposite the load, Item 1 - See Figure 4-11.

2. For narrow aisles, straighten out the truck so it is 8 in. from the edge of the aisle opposite the load Item 2 - See Figure 4-11. For wider aisles, straighten out the truck so it is 36 in. to 48 in. from the side of the aisle where the load is located. Item 6 - See Figure 4-11.
3. Center the forks using the side shift lever.

DANGER

If the forks or load jam or catch during a stacking operation, do not attempt to free them by reaching through the mast.

Failure to follow this instruction can cause serious injury or death.

4. Drive forward until the front edge of the load wheels are aligned with the center of the pallet. Items 3 and 4 - See Figures 4-11 and 4-12.
5. Lift the forks to the required height, and then level the forks using the tilt lever.
6. Stop the forklift and turn the forks 90° using the steering wheel to align them with the load. See Figure 4-13.

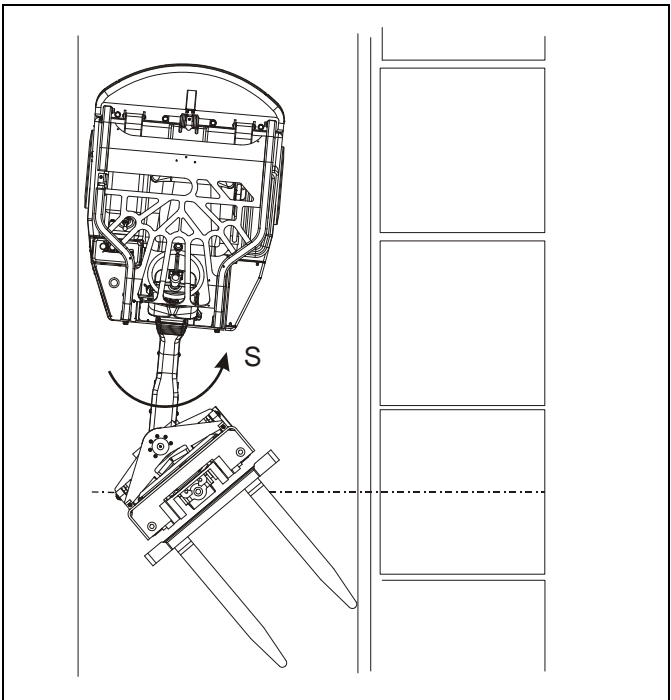

Figure 4-12: Align the Forks

7. Straighten out the forks using the steering wheel as you drive them into the load so the forks enter the load in a straight line. See Figure 4-14.

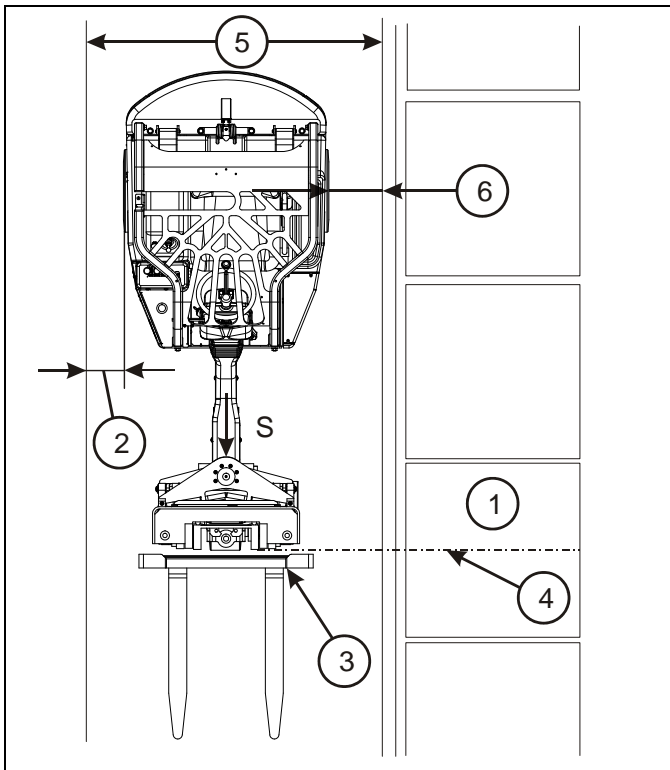

Figure 4-11: Setup - Load Pick Up

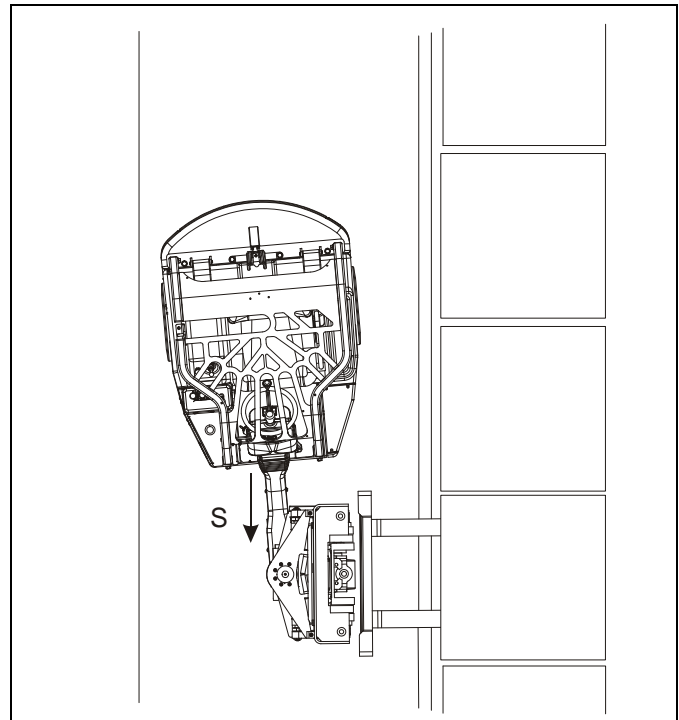

Figure 4-13: Positioning the Forks

8. Turn the steering wheel to keep the forks straight as you fully insert them into the load. Lift, tilt, and side shift as required to stabilize and pickup the load. See Figure 4-15. Only raise the load high enough to clear the rack or the load backrest may catch on the rack.

NOTE

With extreme care and experience, all movement may be controlled to a greater extent by the use of an inching procedure.

9. Shift into reverse and slowly back away from the stack as you turn the steering wheel to keep the forks straight. See Figure 4-16.
10. You may need to side shift as you back out the load to clear the rack.
11. If you still are unable to get enough clearance, drive forward and try the removal process again. To get more clearance, don't start turning the forks until you have backed out 8 in. to 16 in.

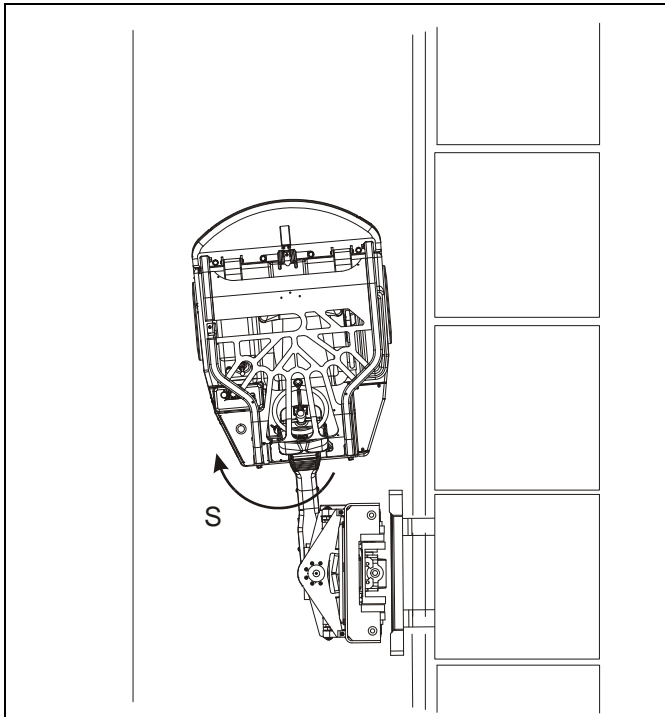

Figure 4-14: Inserting the Forks into the Load

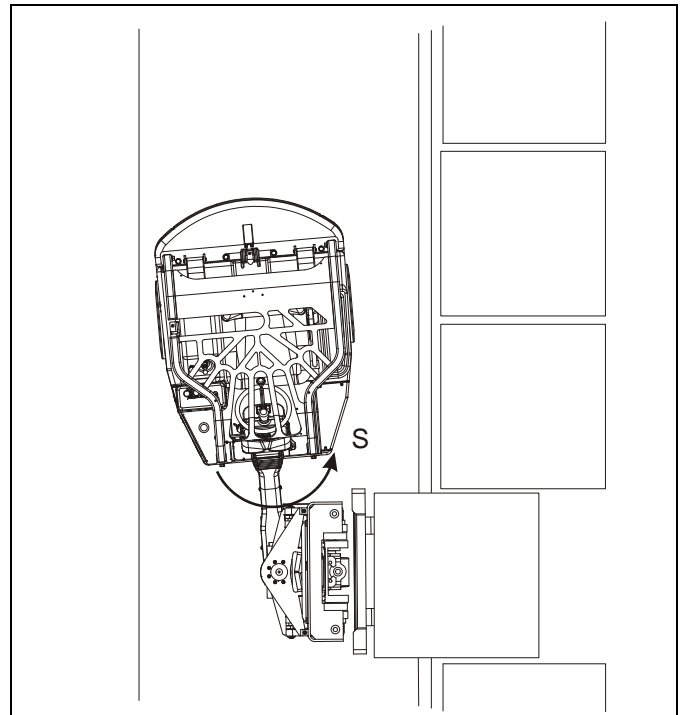

Figure 4-15: Retrieving the Pallet

12. When the front right hand corner of the load clears the rack, stop backing and turn the steering wheel clockwise to straighten out the forks, so they are parallel with the body of the truck. See Figures 4-16 and 4-17.
13. Lower the forks until they are 4 in. to 6 in. off the ground and slowly drive the truck to the next location observing the safety rules previously stated.

! WARNING

Lowering the mast improves driver visibility, and improves the stability of the truck by reducing the possibility of personal injury or damage to the load if it were to slip from the forks.

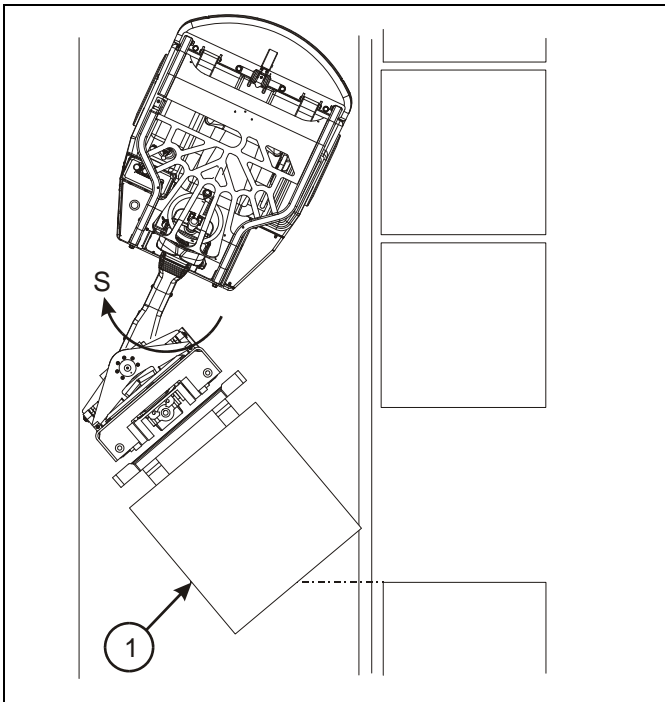

Figure 4-16: Retrieving the Load

- Tilt the mast back.
- Lower the load to recommended traveling position before moving the load to another location.
- Be alert to overhead obstructions such as low doorways, racking and pipes. Make sure you know the raised and lowered heights of the mast.
- Make sure the load is not wider than the width of the gangways or aisles, especially if you are backing a bulky load down an incline.

Traveling on Inclines



DANGER

Use extra caution when operating on ramps.
 Never travel across a grade.
 Travel slowly and do not turn.
 Travel with load uphill.
 Travel with empty forks downhill.
 Failure to follow these guidelines can cause serious injury or death.

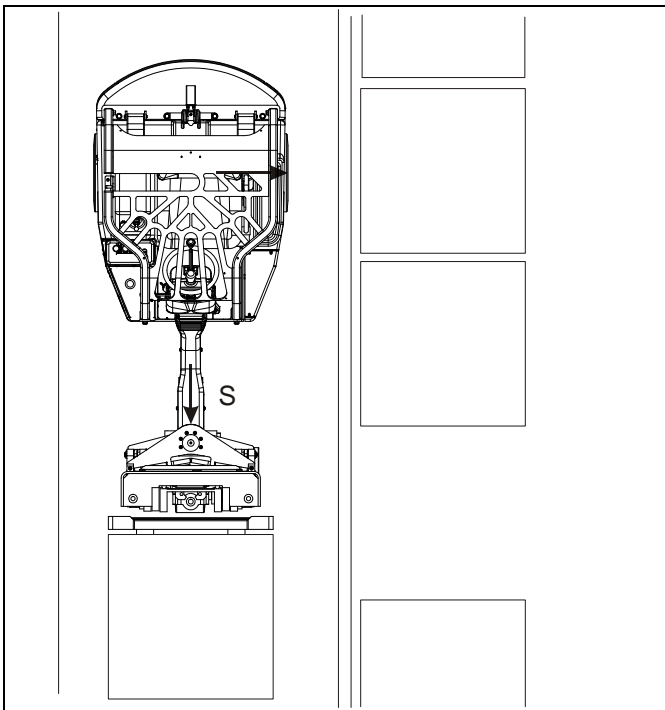

Figure 4-17: Normal Travel Position

When you travel up or down an incline, follow these guidelines:

- Make sure the gradient is 5% or less with a loaded Bendi B40i4 forklift and 8% or less if you are not carrying a load.
- **Always keep the load pointed uphill.** See Figure 4-18. Travel with the forks facing uphill whether you are going up or down an incline. You must then back down an incline when you are carrying a load. If vision is obscured, arrange for a 'Banksman' to guide you.
- If you are not carrying a load, travel with the forks facing uphill when you are going up the incline and face the forks downhill when you are traveling down an incline. See Figure 4-19.
- Raise the forks as necessary to avoid damaging the forks or load as the road surface changes grade at the top or bottom of an incline. Lower the forks to 4 in. to 6 in. off the ground when you clear the incline.

Transporting a Load

Follow these guidelines when you transport a load:

- Do not speed.
- Use your horn to warn others of danger.
- Make sure the load is seated firmly against the fork backrest.

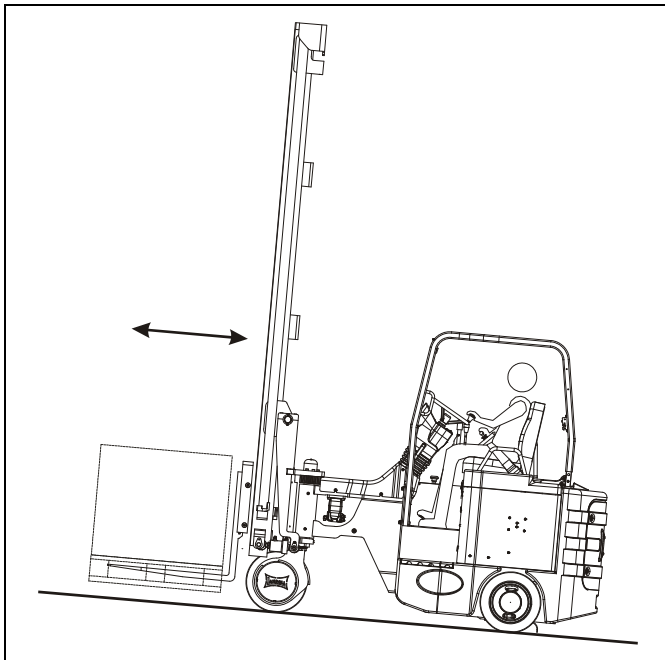

Figure 4-18: Traveling Uphill

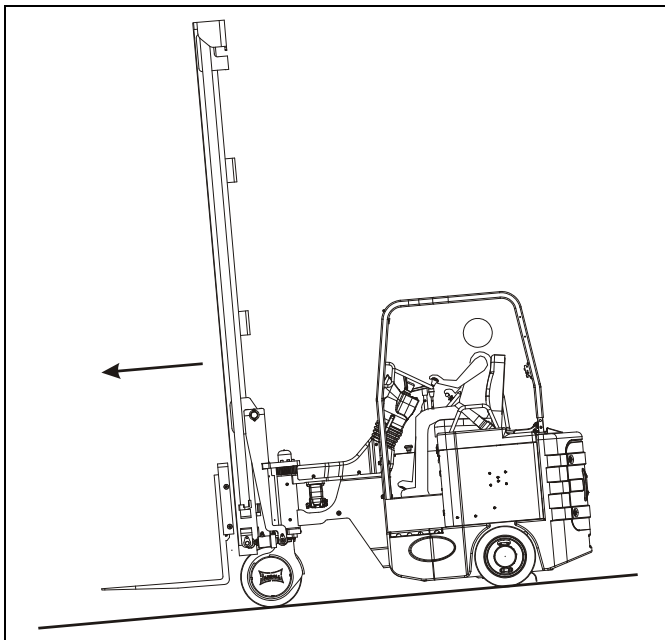

Figure 4-19: Traveling Down an Incline

Unloading the Forklift

NOTES

Actual minimum aisle width may vary based upon application. Item 5 - See Figure 4-20.

The following illustrations show standard 40 in. x 48 in. (W x L) pallets loaded on a rack with 96in. beams. The arrow labeled with an 'S' shows the direction you must turn the steering wheel.

Follow these steps to store a load:

1. Approach the side of the aisle that is opposite the area where you will unload the forklift. Item 1 - See Figure 4-20. For narrow aisles, straighten out the truck so it is 6 in. to 8 in. from the edge of the aisle opposite the drop off point. Item 2 - See Figure 4-20.
2. For wide aisles, straighten out the truck so it is 36 in. to 48 in. from the side of the aisle where the load is located. Item 6 - See Figure 4-20.
3. Center the load using the side shift lever.
4. See Figure 4-20. Drive forward until the front edge of the load wheels, items 3 and 4, are aligned with the center of the rack opening.



DANGER

If the forks or load jam or catch during a stacking operation, do not attempt to free them by reaching through the mast.

Failure to follow this guideline can cause serious injury or death.

5. Lift the load to the proper height.
6. Stop the forklift and turn the load 90° (turn the steering wheel counterclockwise) so it points in the direction you will drop it off. See Figure 4-21.

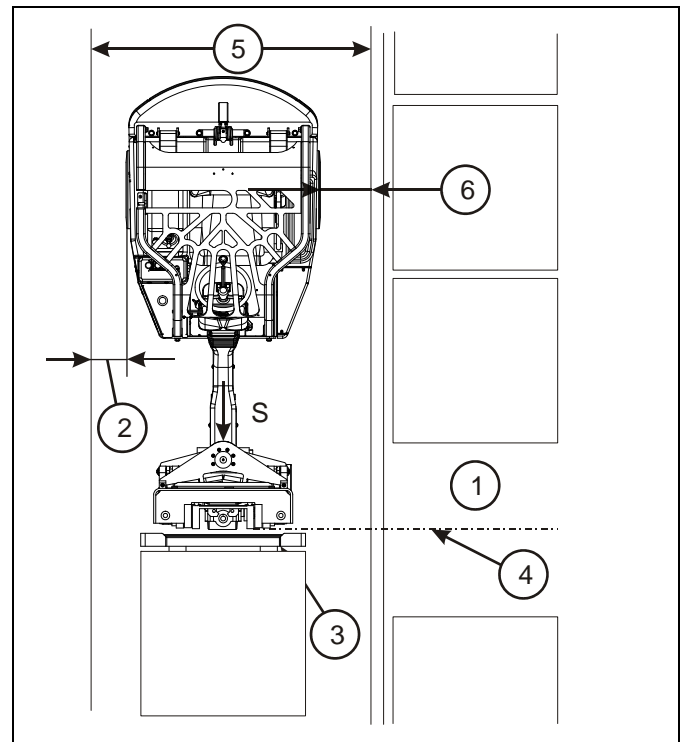

Figure 4-20: Setup - Delivering a Load

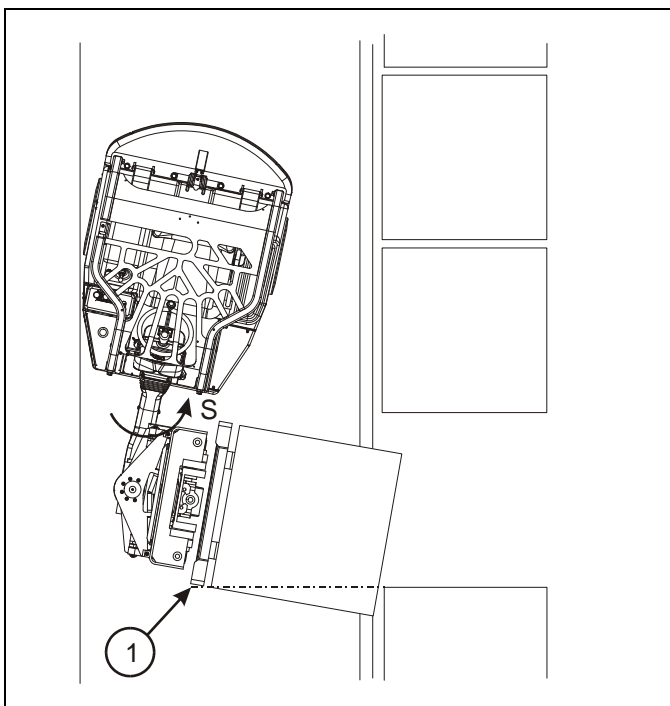

Figure 4-21: Load Drop-Off

7. Drive forward and straighten out the load using the steering wheel so it is square over the stack. See Figure 4-22.

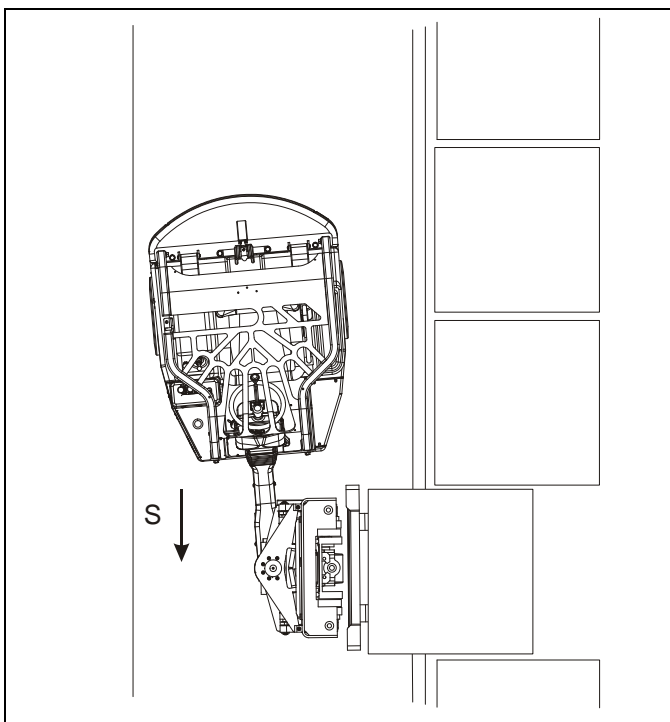

Figure 4-22: Straighten the Load for Drop-Off

8. Turn the steering wheel to keep the load straight as you drive it into the opening. See Figure 4-23.

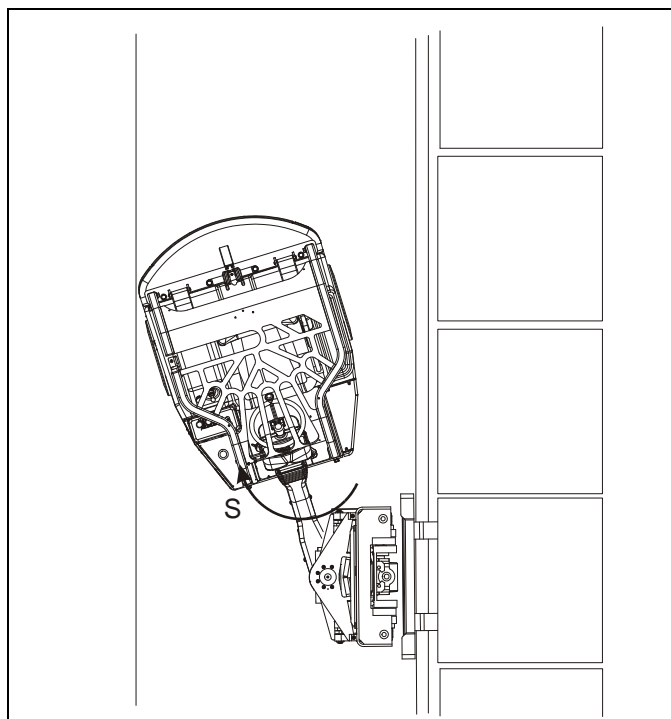

Figure 4-23: Inserting the Load

9. Position the load directly over the rack beams and tilt the mast into its vertical position.



DANGER

When you lower the forks to the “no load” position, make sure you do not lower the forks too far. See Figure 4-24. If the forks are lowered too far beyond the “no load” position, you can damage the mast, rack, or other containers on the stack. This can cause serious injury or death.

10. Lower the forks until the load sits firmly on the rack. Continue to lower the forks until they no longer support the load (‘no load’ position). See Figure 4-24.



DANGER

Do not attempt to withdraw the forks until they have been lowered to a “no load” position. Failure to follow this guideline can cause the load to fall off the stack causing serious injury or death.

NOTE

Do not tilt the mast back until the forks clear the pallet.

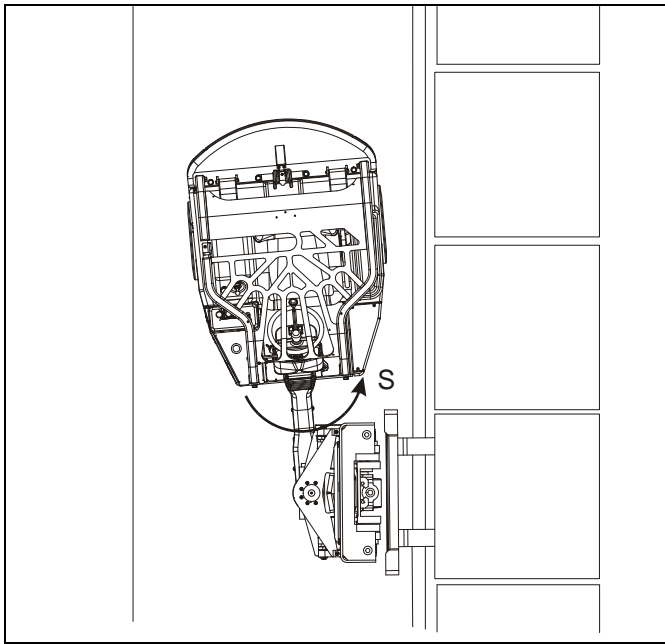

Figure 4-24: No-Load Position

11. Shift into reverse and slowly back out of the load as you turn the steering wheel to keep the forks straight. See Figure 4-25.

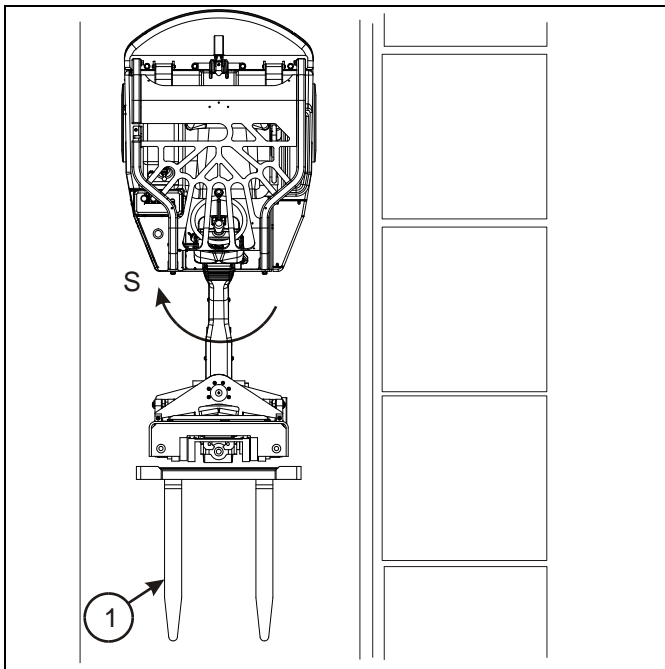

Figure 4-25: Backing Away from the Load

12. When the front right fork clears the rack, stop backing and turn the steering wheel to straighten out the forks so they are parallel with the body of the truck. Item 1 - See Figure 4-25.
13. Lower the forks until they are 4 in. to 6 in. off the ground and slowly drive the truck to the next location observing the safety rules previously stated.

Fire Extinguisher Option

If your truck includes a fire extinguisher it should be inspected monthly or more frequently if circumstances dictate. The extinguisher should be checked to see that:

- it is not damaged
- the discharge outlet is not blocked
- it is fully charged
- the seal is not broken
- the instruction pamphlet is clearly visible

IMPORTANT

Dry-powder extinguishers are shipped fully charged. Do not experiment with your extinguisher since even a small amount of discharge could cause it to slowly lose the rest of its pressure, rendering the extinguisher useless.

In Case of a Fire!



WARNING

Fumes and smoke from any fire may be dangerous and can be deadly. Professionals should handle all fires. Call the fire department, no matter what the size of the fire. Emergency telephone numbers should be posted at each telephone.

The following directions are for general use only, intended to familiarize you with the key functions and procedure of the fire extinguisher. Always check the extinguisher label for specific techniques and starting distances.

1. Have everyone vacate the area immediately.
2. Hold the extinguisher upright and pull the pin.
3. Stand back from the fire the minimum distance indicated on the extinguisher label.
4. Continue to keep the extinguisher upright, compress the handles together to discharge while sweeping the extinguisher from side to side over the fire.
5. Move closer to the area, as the fire is extinguished, BUT NOT SO CLOSE AS TO DISPERSE BURNING MATERIAL.
6. When the fire is extinguished, beware of reignition.
7. Vacate and ventilate the area immediately.
8. Be equipped to leave the area in the event the fire cannot be controlled immediately.

Bendi B40i4 Daily Operator Checks

This Chapter of your Bendi B40i4 Forklift Operator's Manual details the procedures and information the Operator will need to successfully inspect and maintain the truck on a daily basis.

Inspections Overview

Both Daily and Scheduled maintenance procedures are designed to extend the service life of the truck and prevent major problems, causing costly downtime. The Daily Checklist is provided describing routine inspections, adjustments and lubrication necessary to keep your Bendi B40i4 fork lift operating safely, followed by details to facilitate the specific checks.

Maintenance Schedule

A detailed and rigorous full inspection maintenance schedule must be followed and is explained in the "Bendi B40i4 Maintenance Manual", F-581.

IMPORTANT

Read and comply with all applicable SAFETY precautions explained in HEADING AND PAGE. Recommended service inspections are based on normal operating conditions. If the truck is subject to severe or above normal operating conditions, extreme temperatures, excessive dust or wet environments, or if the truck is around corrosive materials, service must be performed more often.

Engine Compartment Access

The driver's seat and side panel are part of the pre-molded engine compartment top cover. The cover includes a mechanical retention latch and pin to secure the engine access cover to the overhead guard when opened. Another hold down latch is provided to secure the cover when closed.



Figure 5-1: Engine Compartment and Access Latch

Daily Checklist

IMPORTANT

Daily Pre-Shift Documented Inspections are an OSHA requirement. Reference page 5-2.

You are responsible for the daily inspection of your Bendi B40i4 forklift:

- Photocopy the "Operator's Daily Checklist" or use the form supplied by your supervisor. See page 5-2.
- Inspect the forklift and fill out the form.
- Report any defect immediately to your supervisor.

Date	Driver	Truck number	Model Number	Location Number	Serial Number	Shift	Hr. Meter	Hydraulic Oil

Operator's Daily Checklist			
Safety and Operational Checks	Condition/Operation	Status	Notes
Fuel Odor	If present, do not start truck! Report immediately		
Forks	Check Top Clip Retaining Pin and Heel conditions		
Load Backrest	Overall condition		
Lift and Lowering Control	Functioning smoothly.		
Tilt Control	Forward and Back functioning smoothly		
Sideshift Control	Functioning smoothly.		
Hang-on Attachment	Functioning smoothly, securely attached, fittings attached		
Steering Operation	Functioning smoothly.		
Drive and Stop Pedals	Functioning smoothly.		
Controls	With power on, investigate any unusual noises immediately		
Dash Display	Functioning properly.		
Horn, Lights, Seat Switch	Functioning properly.		
Parking Brake	Holds forklift in stopped position.		
Drive Control	Forward/Reverse functioning smoothly.		
Engine Air Cleaner	Clean and check dust ejector		
Engine Belt	Check for wear.		
Battery	Check for cracks.		
Hood and Seat Latch	Function properly.		
Capacity Plate	Attached, matches Model, Serial #, and Attachments; Operator's manual in case		
Seat Belt	Make sure buckle and retractors function smoothly		
Overhead Guard	Properly mounted and attached.		
Radiator	Check level in Overflow Tank.		
LPG Hoses	Check for damage, kinks and correct fitting.		
LPG Tank	Securely attached; free of rust, corrosion and damage		
Overall Machine	Keep clean and tidy appearance.		
Engine Oil	Check level.		
Hydraulic Fluid	Check level.		
Tires	Check for debris; Torque Tire Lug Nuts to 205 ft/lb (275 Nm)		
Major Structural Points	Check for cracks in Front Rotation, Mast Braces, Overhead Guard, etc		
Hydraulic System	Check for leaks, noise, and proper function.		
Safety Warnings	Attached.		

Tires and Wheels

The condition of the tires is to be checked along with the lug nut torque setting at the beginning of each shift.

The truck is equipped with tires of a size and hardness that provide the necessary traction and still maintain a proper shape to minimize tipping. To maintain stability and maximum reliability you must always replace tires with the type originally supplied, as listed on the specification sheet at the end of this manual. It is also recommended to replace worn tires in pairs. Treaded drive tires must be replaced when the tread depth is less than 0.0625" (1.6mm) at the deepest point.

1. Inspect the tire for chunking or embedded objects. See Figure 5-2. This is caused by running over objects on a littered floor, overloading or bad driving habits - i.e. sharp, rapid turns at high speeds or rapid starts and stops.

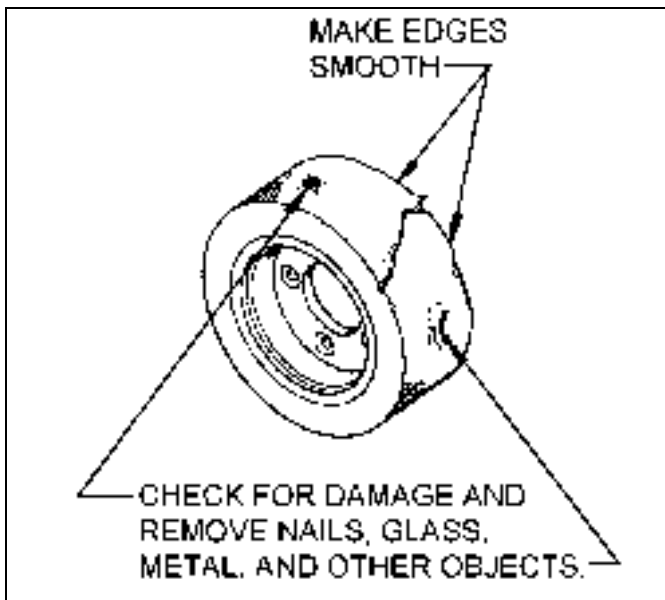

Figure 5-2: Tire Wear and Damage

- Remove any embedded foreign material and torn pieces of tread as soon as it is noticed.
 - Replace chunked tires if it produces a rough ride.
2. Inspect tires for undercutting and uneven wear. Undercutting is caused by continuous overloads, rapid sharp turns, operating on slopes, a faulty steer axle, transporting loads with a high center of gravity or transporting off center loads causing the rubber to bulge out over the edge of the steel band, cutting the rubber just above the base band. Uneven tire wear is usually the result of mechanical defects, such as badly adjusted brakes, misaligned wheels or a faulty drive axle.
 3. Check that the tires remain centered on the wheels to prevent splitting of the base band and tread separation. Correct defects as soon as possible.

4. Flat spotting can occur from excessive heat, a load left on the forks overnight, or locking the brakes with excessive skidding.
5. Avoid oil, grease, gasoline and acid.
6. Torque lug nuts to 205 ft.-lbs. (275 Nm) and make sure no lug nuts are missing.

IMPORTANT

If tires have excessive wear and/or chunking, or lug nuts are missing, repair and/or have service replace them immediately. Do not use the truck until repairs are made.

Parking Brake

The parking brake system on an Bendi B40i4 forklift is manually controlled and is a part of the brake pedal. See Figure 1-3 on page 1-6.

To check the park brake:

1. Sit on the driver's seat and start the engine.
2. Leave the parking brake lever engaged and attempt drive forward at a very slow speed.
3. The park brake should not allow the truck to move.
4. If any problems are found with the operation of the park brake immediately pull the truck from service, repair and do not use the truck.

Accelerator Control

With the engine running and the direction control in the forward position gradually press on the drive pedal. The further you press on the drive pedal the faster the truck will go. Let up on the drive pedal and the truck should come to a controlled stop. Check to make sure the pedal does not stick or catch. If the accelerator functions incorrectly, remove truck from service immediately and repair.

Lift Chains

Primary Lift Chain (Duplex, Triplex and Quadplex Masts)

Visually inspect the chain for cracks, stretched or stressed links and broken pins. When raising the mast listen for usual chain noise and watch the action of the chain for anything unusual. Watch for unusual pulley movement or pulley wobble that would indicate a worn mast bearing.

Forks



CAUTION

- Do not service carriage forks while the Keyswitch is on. If a control lever is accidentally moved, serious injury could occur.
- It is recommended to use only Landoll Corporation replacement parts. Use only quality forks that are forged or have an up-set heel and that have the same capacity rating as the factory installed forks.
- Never use forks repaired by welding.
- Always replace both forks. Switching forks from one truck to another can be dangerous if the capacity of the forks is not known.
- Check the forks for cracks, closely at the heel portion of the forks. Replace the fork if cracks are found. Never attempt to repair, weld or alter a fork.

Electrical Fastener Connections

Check for loose electrical connections and frayed or broken wires.

Hydraulic Cylinders, Fittings & Hoses

Check underneath the truck for evidence of fluid leaks. Look for hydraulic hose wear, damage and leaks. Make sure clamps and fittings are tight. If leaks are found, have service repair all leaks immediately and check the hydraulic fluid level. Do not drive the truck.

Hydraulic Oil

1. Lower the mast to within a few inches of the ground, then tilt it back completely
2. Side shift the mast to the center (normal carry position).
3. With the key switch OFF, turn the steering wheel left and right until it becomes difficult to turn.
4. Open the engine compartment by releasing the latch just under the driver seat in the front of the compartment.
5. Open the right side engine door.
6. Check the fluid level gauge on the right hand side of the tank.
7. Clean the area around the hydraulic fill cap, then open the cap (turn counterclockwise).

IMPORTANT

Do not add Hydraulic oil into the Hydraulic Breather cap.

It is important that the proper level of oil be maintained at all times. Failure to check the oil level as recommended could cause serious mast function operating problems.

8. Add hydraulic oil as needed.
9. DO NOT OVERFILL. With the level above the FULL line, the oil does not have enough area for expansion when it heats up during normal operation.
10. If the fluid appears dirty or dark in color, check the truck's maintenance log for the last fluid and filter change and then change accordingly.
11. Install the fill cap, making sure it is tight.
12. Close and latch the access assembly and doors.

Operator Controls

Lift/Lower Control

With the Keyswitch turned ON, raise the mast. The hydraulic motor should start running as soon as the control is moved out of the neutral position and stop as soon as the control returns to the neutral position. The motor should not run at all when lowering the mast.

Check that the primary mast cylinder extends fully and that the lift carriage rises to the top of the inner rails before the secondary cylinders begin to move.



WARNING

Make sure there is sufficient room above to raise the mast safely and keep all people clear.

When the lift carriage reaches the top of the inner rails the secondary cylinders and middle rails begin lifting. Check to make sure the rails travel smoothly and that there is no chatter or visible binding.

- With the mast fully extended, begin lowering the mast. The secondary cylinders and middle rails fully lower first, followed by the primary cylinder and the lift carriage. Check for smooth travel with no chattering or visible binding.
- If there is noticeable chatter or binding, immediately notify your supervisor or service personnel.
- DO NOT attempt to repair the mast or operate the truck until the problem is corrected.

Tilt Control

Move the tilt mechanism both directions, tilting the mast to both extents, watching for racking. Racking occurs when the tilt cylinder strokes are uneven (One cylinder bottoms before the other). The mast rails then twist, eventually causing them to crack and separate. Proper tilt degree is 3° forward and 3° backward maximum.

1. To check for racking find a reasonably level floor area to park the truck on and center the mast on the truck.
2. Raise the mast about 36" (914 mm) from the floor and tilt the mast full forward and backward several times watching for twisting at the ends of the stroke.
3. If there is any twisting or racking, both tilt cylinder rods must be readjusted. Remove the truck from service immediately and repair.



CAUTION

If the previous scenario is left unattended serious damage to the mast assembly or the tilt cylinders can occur causing extensive repair/downtime.

Side-Shift Control

Hold down the side shift control, moving the mast left and right several times back and forth to both extents. Listen for any abnormal noise that maybe caused by binding in the side-shift mechanism. If any binding is detected apply grease to the bearing pads immediately.

The side shift bearing pads are located within the slide channels above and below the side shift assembly. The channels are lined (sides, top and bottom) with strips of low-friction plastic pads, embedded with molybdenum di-sulfide, an inorganic lubricant. During the first week of operation it is recommended to lubricate these pads once every day to allow the grease to permeate the pads completely. See Figure 5-5.



WARNING

Do not service the side-shift bearing pads while the Keyswitch is ON. If the control is accidentally moved serious injury could occur.

1. Shift the mast to its full left position, as viewed from the operator's compartment and set the Keyswitch to off and remove the key.
2. Before lubricating the bearing pads and channels wipe off any excess lubricant and dirt buildup from within the channels.
3. Using a small brush paint a thin film of grease to the sides, top and bottom of the side-shift channel surfaces reachable with the mast in this position.

4. Apply a little extra grease to the top surface of the bottom channel pads.
5. Turn the truck back on and shift the mast to its full right position and then turn Keyswitch back to the off position and remove key.
6. Repeat grease procedure that was done on the left side.

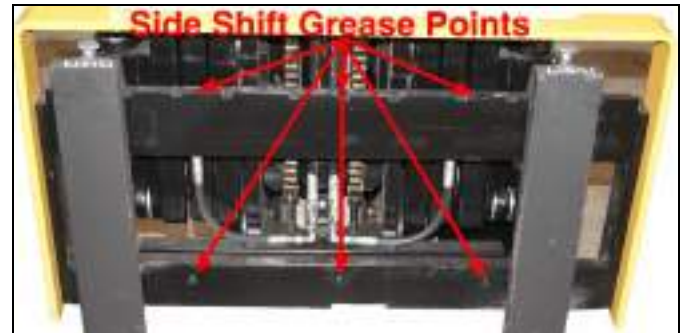

Figure 5-3: Side Shift Grease Points

Directional Control

Rock the directional switch forward to put the truck in forward operation. Verify control input by observing direction arrow on dash display. Repeat for the reverse direction by rocking the direction switch backwards.

Static Return to Off (SRO) Function

The static return to off (SRO) is a built in safety feature to prevent accidental truck movement.

To check the SRO:

1. Get in the operator's seat, drive the truck forward, and then come to a stop. Leave the directional control switch in the forward position and turn the Keyswitch to the off position.
2. Turn Keyswitch back to the on position and then press on the accelerator. The truck should not move. Cycle the directional switch to neutral and then back to forward. The truck should now operate correctly.
3. Next, drive the truck forward and come to a stop leaving the directional control switch in the forward position.
4. Lift yourself out of the seat for three seconds. Sit back down and then press on the accelerator. The truck should not move without cycling the directional switch back through neutral.

Auxiliary Function Controls (Optional)

If your truck is equipped with an auxiliary hydraulic attachment, such as a fork positioner, sit in the driver's seat and turn the truck on. Press and hold the auxiliary function control mechanism, moving the control forward and aft. Watch the attachment to determine if it functions properly. If abnormalities are found remove the truck from service and repair.

Horn

Press the horn button located to the right of the direction control lever, near the mast levers. Make certain the horn sounds when button is pushed.

Lights and Alarm

Check lights for proper on/off operation. Check that alarms sound when intended. Repair and/or replace as needed.

Steering

Before operating the truck check the steering system to make sure it operates correctly.

To check the steering system:

1. Get in the operators seat and start the engine.
2. Disengage the parking brake.
3. Next, while moving forward or backwards slowly, turn the steering wheel clockwise until the steering wheel locks. The front steer wheel should have turned clockwise. Repeat turning the steering wheel counterclockwise and the front steer wheel should turn counterclockwise.
4. While turning the steering wheel there should be a little resistance felt and the steering wheel should not move once the front steer wheel stops rotation.

Steer Column Tilt & Telescope

Before operating the truck adjust the steer column tilt and telescope in a comfortable position and torque the levers tight to ensure the steer column stays locked in place during operation.

Dash Display

Inspect the dash display for errors or faults and ensure that the display reads normal. Check hour meter to ensure everything looks normal. If any abnormalities are found remove the truck from service immediately, for repair.

Seat, Belt, Slides & Switch

Check the seat covering for rips or cuts. Check seat belt straps for cuts, worn or frayed areas. Make certain seat slides and adjustments lock in position. Check that the seat belt is firmly attached and that the buckle is not damaged. Check that the seat belt works properly. There is a switch in the seat that detects operator presence. The driver's seat switch system includes an interlock that shuts down the drive and disables the direction control (resets to NEUTRAL) bringing the truck to a Stop. The mast functions remain operable.

To check the seat switch interlock:

1. Get in the operator's seat, drive the truck forward and then come to a stop leaving the directional control switch in the forward position.
2. Lift yourself out of the seat for three seconds. Sit back down and then press on the accelerator. The truck should not move without cycling the directional switch back through neutral. If this interlock does not work, remove the truck from service and repair. Do not use the truck.

Major Structural Points

Rust or Corrosion

Check the truck frame, side and floor panels for rust and corrosion. Clean rusty or corroded areas and repaint, if applicable. Apply a thin coat of oil to any bare metal surface.

NOTE

Immediately remove truck from service and repair if frame cracks are found.

Overhead Guard

Check the overhead guard, making sure that it is firmly attached to the truck and that all fasteners are secured. The overhead guard is adjustable to accommodate various drivers' and operating restrictions (low ceilings, door openings, etc.).

Safety Labels

Check for damaged and missing decals. Check that the decals are legible. Clean and/or replace as needed. (See Figure 1-1 on page 1-3 and Figure 1-2 on page 1-4)

Capacity/Identification Plate

The capacity plate should be checked to verify capacity ratings and lift heights. Also check the serial number of the truck and mast to make sure they match up with the corresponding numbers on the capacity plate. See Figure 3-3.

Unusual Noises

The operator, as well as the maintenance technician, should be aware and take action on any unusual noises that may surfaced.

The type of noise, such a grinding or a growl, as well as the location of the noise can determine if or what type of maintenance needs to be taken.

Most grinding noises may indicate a need for mast rail lubrication or a faulty wheel bearing.

Growling noises can indicate faulty hydraulic pumps or simply low oil in the hydraulic tank.

Any unusual noises should be noted in the daily check sheet and reported to the person in charge of repairs and maintenance immediately.

General Truck Lubrication

Inspect lubrication points. See Figures 5-4 and 5-5.

These lubrication points along with proper recommended lubricants ... See Table 5-1 on page 5-7 ... are designed to extend the service life of the truck and prevent major problems, causing costly downtime.

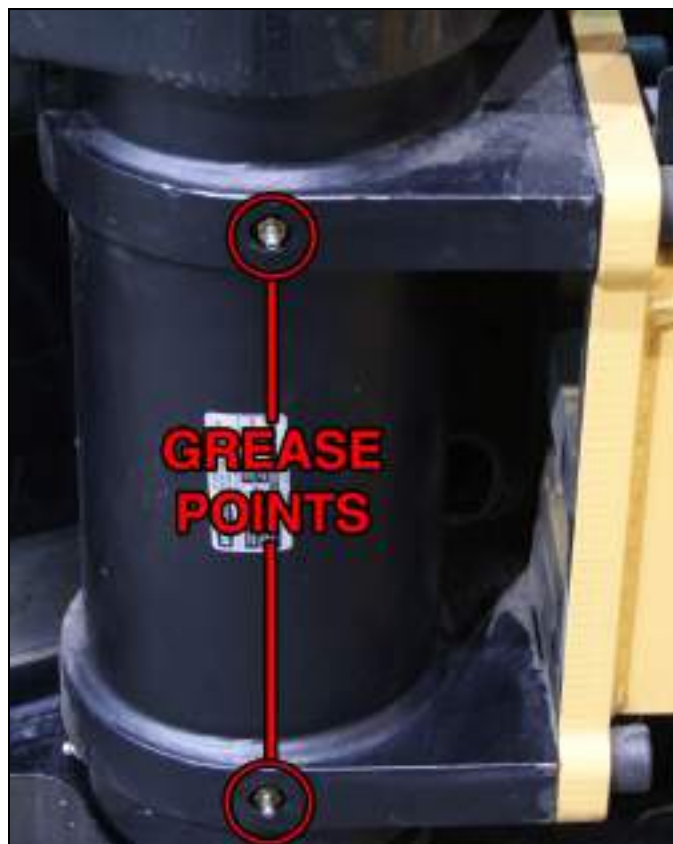

Figure 5-4: Rotation Bearing Grease Points

Recommended Lubricants

See Table 5-1 below for recommended lubricants. For specific areas to lubricate the forklift - See Figure 5-5.

Table 5-1: Lubrication Chart

Name	Lubrication	Comments
1. Chain	SAE40W oil or Bowman Heavy Load Red Grease	Clean and recoil
2. Upright Rail	Chassis Lube or Kendall SR-12X	Lubricate inner sides of upright rails
3. Rotation Bearings	Texaco Ref. C & C #880	Use standard lubrication gun
4. Steering Knob	Light weight oil	Lightly oil
5. Engine	SAE 10W30 API "SL"	Drain, flush and refill
6. Hydraulic Reservoir	Conoco Power flow HE (ISO Grade 46) Filtered to ISO 4406 cleanliness code 15/13/11 or equivalent Grade oil filtered to 15/13/11.	Drain, flush and refill
7. Tilt Cylinders	Texaco Ref. C & C #880	Use standard lubrication gun
8. Articulating Axle Bearings	Texaco Ref. C & C #880	Use standard lubrication gun
9. Load Wheel Axle	Texaco Ref. C & C #880	Use lubrication gun and adapter for flush type fittings
*Failure to refill with oil that meets ISO 4406 cleanliness code 15/13/11 may void the warranty. Typical "NEW" oil DOES NOT meet this specification. Contact Landoll Corporation or your lubricant supplier for recommendation.		

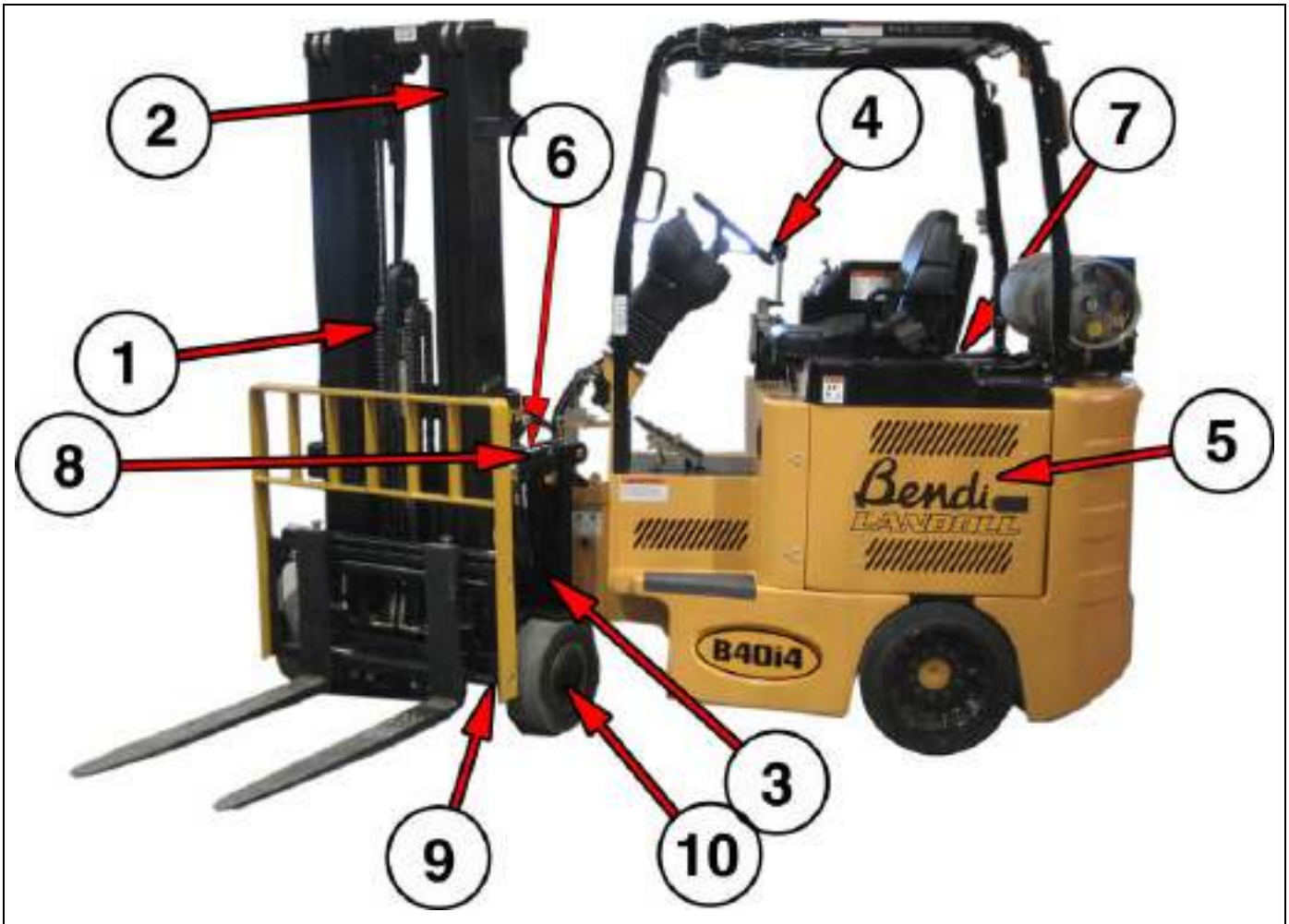

Figure 5-5: Lubrication Points

Technical Specifications

Table 5-2: Standard Specifications

Model	B40i4
Capacity @ 24" Load Centers	4,000 lbs. / 1,814 kg
Load Center	24 in. / 600 mm
Weight Total Front Rear	13,140 lbs. / 5,966 kg 3,500 lbs. / 1,589 kg 9,640 lbs. / 4,377 kg
Travel Speed	8 MPH / 13 KPH
Lift Speed Loaded Unloaded	90 fpm / 27 mpm 70 fpm / 21 mpm
Lower Speed Loaded Unloaded	60 fpm / 18 mpm 90 fpm / 27 mpm
Mast Tilt (Forward/Reverse)	3° / 3°
Standard Forks (ITA Class II)	40 x 4 x 1.5 in. / 1016 x 101 x 38 mm
Gradeability (Loaded)	15% Empty, 15% Loaded
Engine GM 2.4L HP Rating Fuel Battery Voltage Traction	4 cyl. 60 hp @ 2,400 RPM LPG 12 Volt Hydrostatic
Front Articulation	180° - Full Left to Full Right Travel
Wheel Sizes Front (1 each) Rear (2 each)	14 x 5 in. / 360 x 130 mm 18 x 7 in. / 460 x 180 mm

**Technical Specifications Subject to Change.*

Document Control Revision Log:

Date	Revision	Improvement(s) Description and Comments
03/01/11	F-580-R1	Initial Release-Joshua
11/02/16	F-580-R1	Hydraulic fluid change - Joshua



Intertek

Equipment from Landoll Corporation is built to exacting standards ensured by ISO 9001 registration at all Landoll manufacturing facilities.

Bendi Model B40i4 Narrow Isle Forklift Operator's Manual

Re-Order Part Number F-580-R1

LANDOLL CORPORATION

1900 North Street

Marysville, Kansas 66508

(785) 562-5381

800-428-5655 ~ WWW.LANDOLL.COM



Copyright 2016. Landoll Corporation

"All rights reserved, including the right to reproduce this material or portions thereof in any form."