



# Log Book

## For the Moffett Truck-Mounted Forklift



Delivering **Confidence**

<b>TABLE OF CONTENTS</b>
--------------------------

**INTRODUCTION / OBJECTIVES .....2**

**OPERATORS GUIDE .....3**

**DAILY CHECKS OR TAKEOVER PROCEDURES.....4**

**MOVING MAST MAJOR COMPONENTS .....5**

**STATIC MAST MAJOR COMPONENTS.....6**

**MAJOR COMPONENTS .....7**

**MAINTENANCE SCHEDULE .....8**

**MAINTENANCE SCHEDULE ALL MODELS.....9**

**MAINTENANCE SCHEDULE ALL MODELS.....10**

**RECORD OF SERVICE INTERVALS .....11**

**RECORD OF SERVICE INTERVALS .....12**

**RECORD OF SERVICE INTERVALS .....13**

**RECORD OF SERVICE INTERVALS .....14**

**RECORD OF SERVICE INTERVALS .....15**

**RECORD OF DAMAGE .....16**

**RECORD OF TRANSFER OF FORKLIFT .....17**

**NOTES .....18**

## **INTRODUCTION / OBJECTIVES**

Thank you for choosing a Moffett truck-mounted forklift. This log book outlines the daily checklist and maintenance schedule for your Moffett truck-mounted forklift. Please understand and follow all information given in the operator manual and this log book before operating the machine. Always store the log book with the operator manual in the manual box located on the back of the driver's seat.

Do not drive any forklift that is unsafe or unfit for use, or attempt to repair it yourself. Forklift repairs, other than daily checks and maintenance, must only be carried out by a Moffett trained service engineer.

In the interest of safety we would recommend using only original Moffett parts. Moffett Engineering Ltd and Moffett bv. cannot be held liable for non approved part(s) that are fitted to your machine.

Original parts and related products that have been approved by Moffett can be obtained from all official Moffett dealers and importers.

It is the responsibility of the operator to ensure that the checks listed on page 7, plus any others recommended in respect of a particular forklift, are carried out. In this way the risk of accidents to persons and materials can be reduced, as can the time needed for repairs and breakdowns caused by lack of correct reporting.

## OPERATORS GUIDE

THE OPERATOR SHOULD	THE OPERATOR SHOULD NOT
Familiarise yourself with the forklift before commencing work. Mount and dismount the correct way,	Do not use a forklift unless you have a correct current operator licence and written authorisation to drive.
Carry out daily checks. See and fill out forklift log book. Report any faults.	Do not attempt to operate a forklift if you have consumed alcohol or drugs.
Read and understand the manufacturers operator handbook.	Do not use any special forklift or attachment until specific job training is undertaken.
Observe site regulations, company safety policy and fire policy. Use safety protection where appropriate.	Do not use any forklift that has not been checked or is unsafe to use.
Study the job. Can the forklift complete the work safely? Use extreme caution when working with heavy or awkward loads.	Never overload, undercut or use any forklift outside its rated capacity. Never turn or travel with the load elevated.
Plan ahead, take special care on inclines or rough ground, particularly wet surfaces.	Do not operate the hydraulics when travelling. Never apply the forward tilt with a load.
Pay attention - Drive carefully and slowly, look in the direction of travel, sounds horn at corners, doorways and obstructions.	Do not fool around, show off or carry passengers on the body or the forks.
Report any accident or 'near miss' to your supervisor or safety officer immediately.	Never smoke in the vicinity of forklifts or fuel pumps.
	Do not leave your truck out of fuel or with a flat battery.
	Never use any forklift on the public highway without observing the public highway regulations.

## **DAILY CHECKS OR TAKEOVER PROCEDURES**

### **INTRODUCTION**

To keep any forklift running efficiently and safely for the maximum time, a planned system of inspection and maintenance is necessary. It is the forklift operator's responsibility to check his forklift daily or on take-over from another person and to carry out simple daily checks and preventative maintenance. A conscientious operator who does this regularly and diligently is not only assuring himself that the forklift is safe and fit for use, but is also saving his company money by extending the forklift's useful life and keeping repair costs to a minimum.

### **METHOD**

The first task is to check the log book to ensure that any faults previously reported have been put right. If any have not been rectified, the fact should be reported immediately to the foreman or supervisor. The operator should then carry out a systematic check of the forklift, depending on type of forklift.

### **RECORDS**

The daily checks carried out must be recorded and the condition of the forklift entered in the log book, initialled by the operator who carried out the inspection and by a responsible supervisor.

### **REPAIRS AND MAINTENANCE**

Do not drive any forklift that is unsafe or unfit for use, or attempt to repair it yourself. Forklift repairs, other than daily checks and maintenance, must only be carried out by a trained competent engineer.

### **CONCLUSION**

It is the responsibility of the operator to ensure that the checks listed in this log book, plus any others recommended in respect of a particular forklift, are carried out. In this way the risk of accidents to persons and materials can be reduced, as can the time needed for repairs and breakdowns caused by lack of correct reporting.

## MOVING MAST MAJOR COMPONENTS

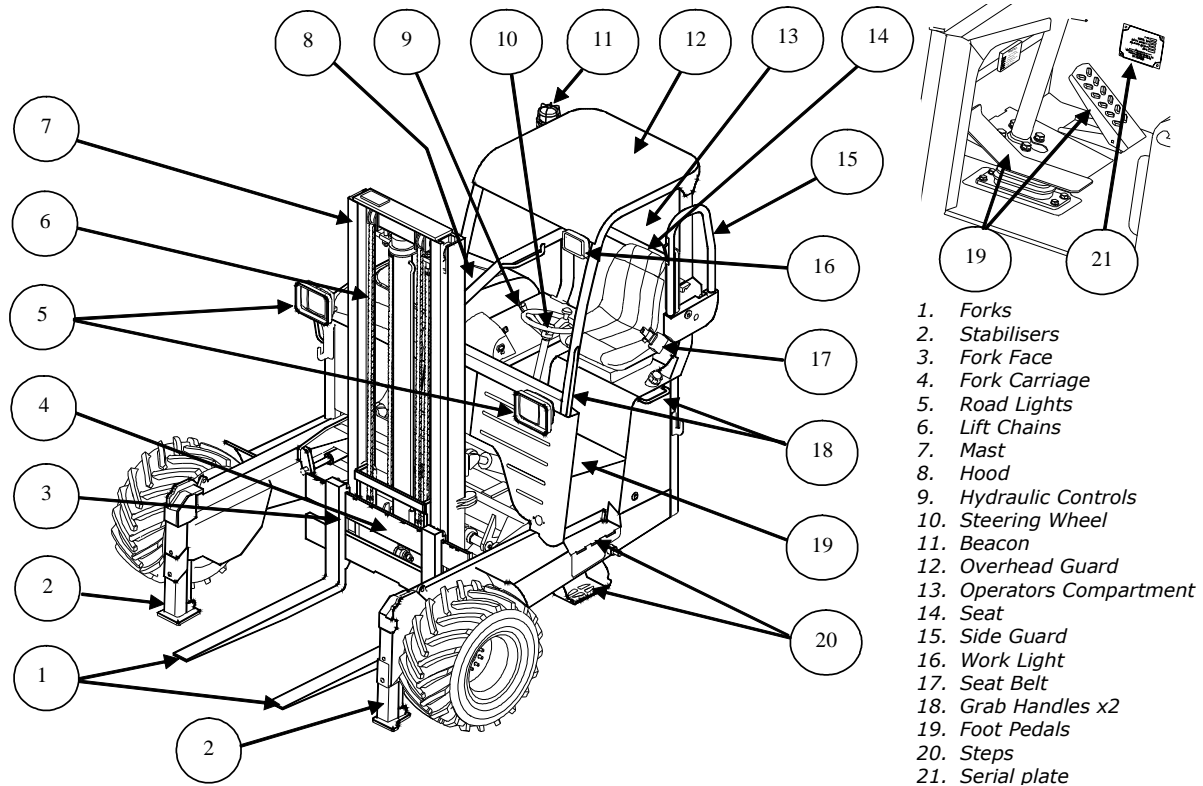

**STATIC MAST MAJOR COMPONENTS**

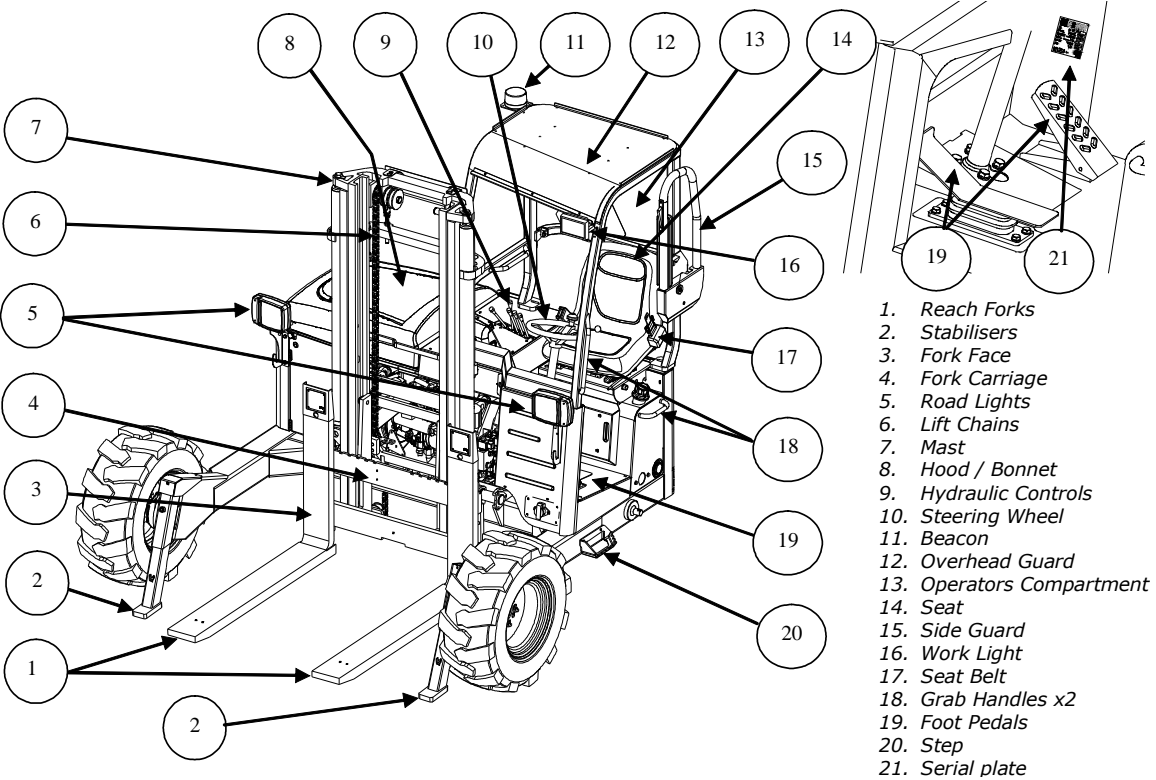

<b>MAJOR COMPONENTS</b>		
	<b>COMPONENT</b>	<b>DAILY CHECKLIST</b>
1.	Forks	Fork Latches - Hangers - Distortions cracks
2.	Stabilisers	Damage - Wear - Pins are secure - Oil leaks
3.	Fork Face	Wear - Cracks - Fork face is straight
4.	Fork Carriage	Wear - Cracks - Fork carriage is straight
5.	Road Lights	Check all lights are working
6.	Lift Chains	Cleanliness and lubrication not slack or loose
7.	Mast Assembly	Check for cracks -Damage - Foreign Bodies - Slowly operate mast controls Raise & lower mast - Tilt forks forward & back - Extend & retract mast All should operate smoothly
8.	Hood & Engine Compartment	Oil & Coolant levels - Visual inspection, leaks, fan belt, radiator, loose items - Run engine for unusual noises..
9.	Hydraulic Controls.	Slowly operate all controls - All should operate smoothly
10.	Steering	Check for play and smooth operation - Check 4-Way operation where fitted
11.	Beacon	Should operate when ignition is turned on
12.	Overhead Guard	Check for damage
13.	Operators Compartment	Should be clean - No loose items
14.	Seat	Should be secure - Check for signs of damage - Check seat adjusters
15.	Side Guard	Check for damage - Should lock in the up or down position
16.	Work Light	Check all work lights work correctly
17.	Seat Belt	Should be secure - No damage or fraying - Should operate correctly
18.	Grab Handles	Should be secure - No damage to handles
19.	Foot Pedals	Should be clean - should return to the neutral position when released
20.	Steps	Free from dirt / soil
21.	Serial Plate	Should be secure - No damage
22.	Attachments	Check for cracks -Damage - Foreign Bodies - Slowly operate attachment controls.



## MAINTENANCE SCHEDULE

The maintenance schedule given below applies to Static mast machine's when used under normal operating conditions. Contact your Moffett service point if you have any questions. Bring the machine to a Moffett service point if:

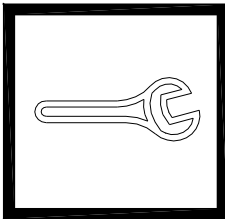

The warning light as shown to the side lights up and the following message is shown on the display.

Only a recognised Moffett service dealer can reset the service maintenance reminder and, thus, enter the next overhaul in the MMS (Machine Management System).

**MAINTENANCE SCHEDULE ALL MODELS**

<b>Maintenance Specifications Chart</b>	
<b>Code</b>	<b>Operation</b>
CH	Change
CK	Check
G	Grease
CL	Clean
D	Drain
A	Adjust

<b>SERVICE DETAILS</b>			
<b>Operation</b>	<b>First Service at 50 Hrs or 60 days</b>	<b>Next Service at 200 Hrs or 240 days and every additional 200 Hrs or 240 days</b>	<b>* Additional Items required at 1000 Hrs or 1200 days</b>
Change engine oil & oil filter element	CH	CH	
Change engine air filter element	CK	CH	
Change inline & main fuel element	CH	CH	
Change hydraulic filter elements (suction/return)	CH	CH	
Change hydraulic intank filter elements			CH
Change hydraulic oil			CH
Check/replenish coolant	CK	CK	
Check all bolts/nuts/fittings for tightness	CK/A	CK/A	
Check fan belt tension	CK/A	CK/A	
Carry out full electrical operational checks	CK	CK	
Carry out full hydraulic operational checks	CK	CK	
Adjust and lubricate lift chains	CK/A	CK/A	

**MAINTENANCE SCHEDULE ALL MODELS**

<b>Operation</b>	<b>First Service at 50 Hrs or 60 days</b>	<b>Next Service at 200 Hrs or 240 days and every additional 200 Hrs or 240 days</b>	<b>* Additional Items required at 1000 Hrs or 1200 days</b>
Grease all moving parts manually at specific grease points	G	G	
Check all wheel nuts for tightness (see Wheel Nut Specification Chart)	CK/A	CK/A	
Check all mast/carriage bearings for operation/wear	CK/A	CK/A	
Check rear arm bearings/bushings for operation/wear	CK/A	CK/A	
Check condition of tyres/rims	CK	CK	
Check for play in mast sections/carriage section	CK	CK	
Check mast lift chains for wear/missing parts/elongation	CK/CH	CK/CH	
Check/inspect condition of forks	CK	CK	
Check/inspect condition of seat/seat belt/overhead guard	CK	CK	
Check/inspect machine for all safety/functional decals	CK	CK	
Check oil cooler operation (if fitted)	CK	CK	
Test drive machine with/without weight	CK	CK	
Check transport lights on Moffett truck-mounted forklift with parent Truck/Trailer	CK	CK	
Inspect stabilizing chains for wear/missing/broken parts	CK	CK	
Check engine idling speed	CK/A	CK/A	
Check/adjust valve clearance on engine			CK/A
Remove radiator and clean all dust etc from between fins			CK/CL

<b>RECORD OF SERVICE INTERVALS</b>
------------------------------------

Service Type: ___ Hours: ___	
Date:	Signature:
Hour Count:	Company Stamp:
Remarks:	
Next Service:	Related Service Bulletin:

Service Type: ___ Hours: ___	
Date:	Signature:
Hour Count:	Company Stamp:
Remarks:	
Next Service:	Related Service Bulletin:

Service Type: ___ Hours: ___	
Date:	Signature:
Hour Count:	Company Stamp:
Remarks:	
Next Service:	Related Service Bulletin:

Service Type: ___ Hours: ___	
Date:	Signature:
Hour Count:	Company Stamp:
Remarks:	
Next Service:	Related Service Bulletin:

**RECORD OF SERVICE INTERVALS**

Service Type: ___ Hours: ___	
Date:	Signature:
Hour Count:	Company Stamp:
Remarks:	
Next Service:	Related Service Bulletin:

Service Type: ___ Hours: ___	
Date:	Signature:
Hour Count:	Company Stamp:
Remarks:	
Next Service:	Related Service Bulletin:

Service Type: ___ Hours: ___	
Date:	Signature:
Hour Count:	Company Stamp:
Remarks:	
Next Service:	Related Service Bulletin:

Service Type: ___ Hours: ___	
Date:	Signature:
Hour Count:	Company Stamp:
Remarks:	
Next Service:	Related Service Bulletin:

**RECORD OF SERVICE INTERVALS**

Service Type: ___ Hours: ___	
Date:	Signature:
Hour Count:	Company Stamp:
Remarks:	
Next Service:	Related Service Bulletin:

Service Type: ___ Hours: ___	
Date:	Signature:
Hour Count:	Company Stamp:
Remarks:	
Next Service:	Related Service Bulletin:

Service Type: ___ Hours: ___	
Date:	Signature:
Hour Count:	Company Stamp:
Remarks:	
Next Service:	Related Service Bulletin:

Service Type: ___ Hours: ___	
Date:	Signature:
Hour Count:	Company Stamp:
Remarks:	
Next Service:	Related Service Bulletin:

**RECORD OF SERVICE INTERVALS**

Service Type: ___ Hours: ___	
Date:	Signature:
Hour Count:	Company Stamp:
Remarks:	
Next Service:	Related Service Bulletin:

Service Type: ___ Hours: ___	
Date:	Signature:
Hour Count:	Company Stamp:
Remarks:	
Next Service:	Related Service Bulletin:

Service Type: ___ Hours: ___	
Date:	Signature:
Hour Count:	Company Stamp:
Remarks:	
Next Service:	Related Service Bulletin:

Service Type: ___ Hours: ___	
Date:	Signature:
Hour Count:	Company Stamp:
Remarks:	
Next Service:	Related Service Bulletin:

**RECORD OF DAMAGE**

Date	Name	Brief Details of Damage or Accident	Job No.	Reported To



**RECORD OF TRANSFER OF FORKLIFT**

Date	Transferred From	Comments	Transport No.	Transferred To

**NOTES**

